

CEPC Electromagnetic Calorimeter

Yong Liu (IHEP), for the CEPC calorimetry team

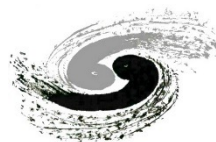

中國科學院高能物理研究所
Institute of High Energy Physics
Chinese Academy of Sciences

Content

- **Introduction**
- **Requirements**
- **Technology survey and option selection**
- **Technical challenges**
- **R&D efforts and results**
- **Detailed design including electronics, cooling and mechanics**
- **Readout electronics**
- **Performance from simulation**
- **Research team and working plan**
- **Summary**

Introduction

RefDet TDR Outline

Chapter 6 Electromagnetic calorimeter

6.1	Introduction
6.2	Requirements
6.3	Survey of ECAL technical options
6.3.1	Silicon-tungsten ECAL
6.3.2	Scintillator-tungsten ECAL
6.3.3	Crystal ECAL
6.3.4	ECAL option selection for the reference detector
6.4	Critical issues and technical challenges
6.5	R&D efforts and results
6.6	Designs including electronics, mechanics and cooling
6.7	Performance from simulation and beamtests
6.8	Summary

Separation of Higgs hadronic decays in jets

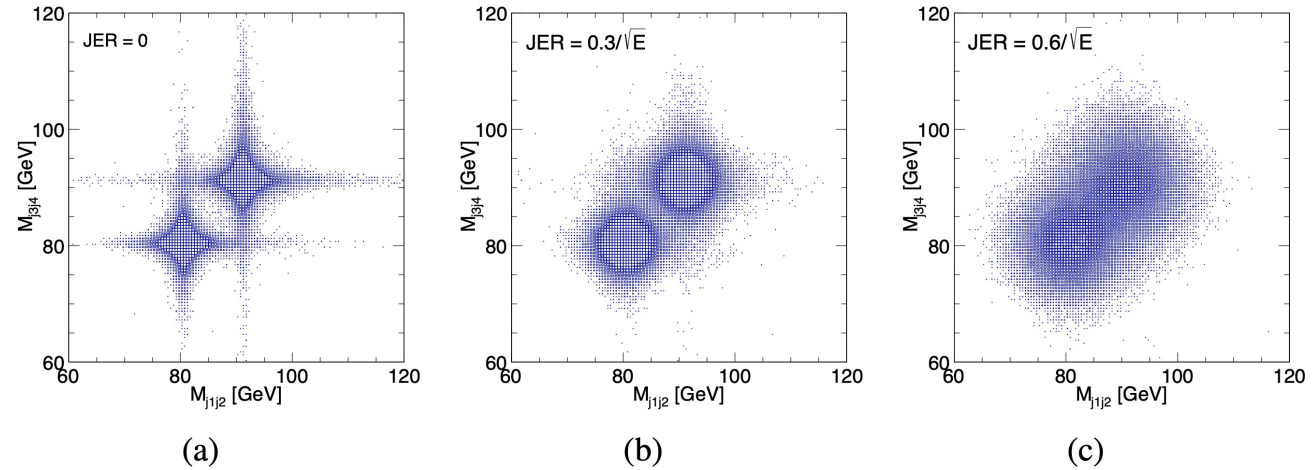

- This talk is about the design and developments of the electromagnetic calorimetry system (related to the RefDet TDR Chapter 06)
- General remarks: the calorimetry system (in the CEPC reference detector) will be based on the particle-flow paradigm → high granularity in 3D
 - Aim to achieve an unprecedented Boson Mass Resolution (BMR) of 3 – 4%

ECAL requirements

Parameter	Conservative	Ambitious	Remarks
EM energy resolution	$\sigma_E/E = 15\%/\sqrt{E(\text{GeV})}$	$\sigma_E/E = 3\%/\sqrt{E(\text{GeV})}$	Jet performance; flavor physics
Longitudinal Granularity and Depth	26 – 30 layers, total depth of $24X_0$		Full containment of EM showers
Transverse Granularity	$10 \times 10 \text{ mm}^2$		$H \rightarrow gg$ (gluon jets); $Z \rightarrow \tau\tau$
Signal Dynamic Range	0.1 MIP - 3000 MIPs		0.1 MIP as trigger threshold; Bhabha electrons at 360 GeV
Time Resolution (1-MIP signal)	1 ns	0.5 ns	Bunch crossing ID; timing to improve clustering and hadron performance
Power Consumption (per channel)	15 mW/ch		$\sim 10^6$ channels in final detector

Technical option survey

■ Three major options for CEPC electromagnetic calorimeter

- Silicon-tungsten (SiW): sampling calorimeter
- Scintillator-tungsten (ScW): sampling calorimeter
- Crystal: homogeneous calorimeter (new!)

Highly granular (imaging) calorimetry
+ particle flow algorithm (PFA)

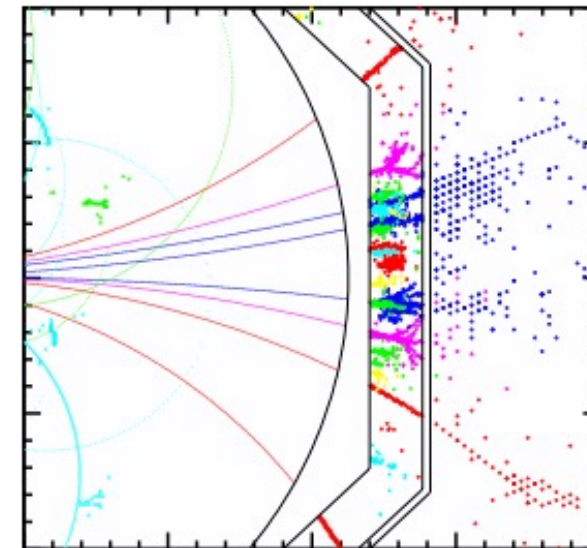
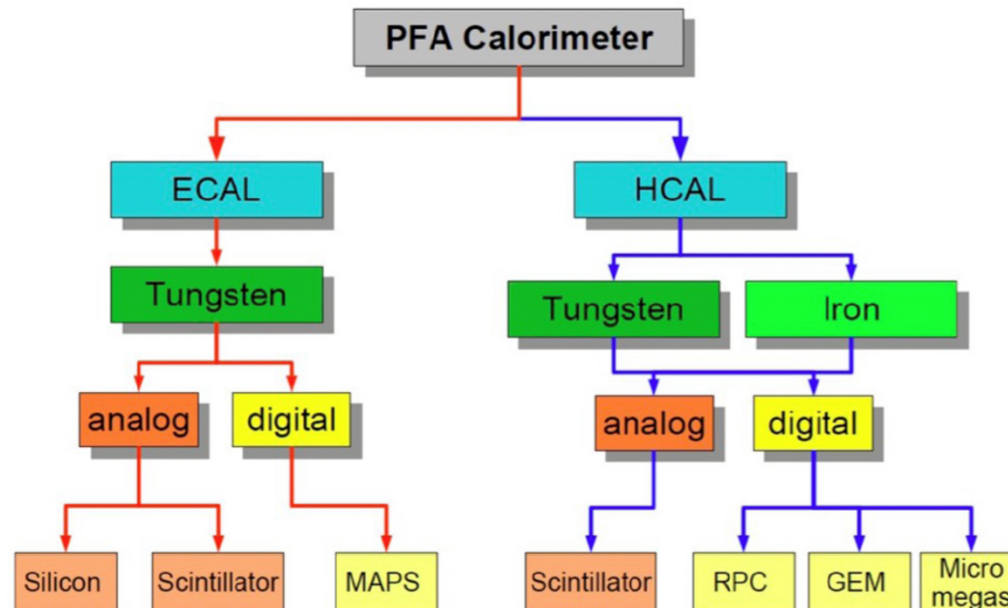

PFA calorimetry: various options explored in the CALICE collaboration in past 20 years

SiW-ECAL option

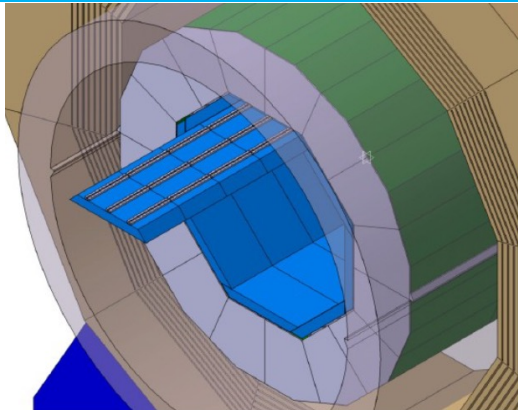

CALICE SiW-ECAL Physics Prototype

Silicon sensors+ CuW

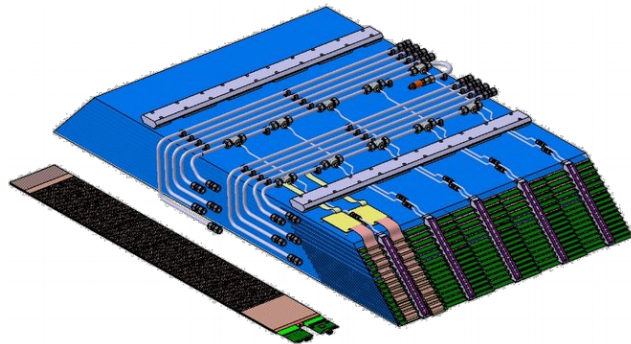

92mm long (6" wafer)

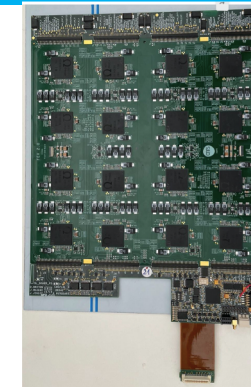

CALICE SiW-ECAL Technological Prototypes

Stacking structure

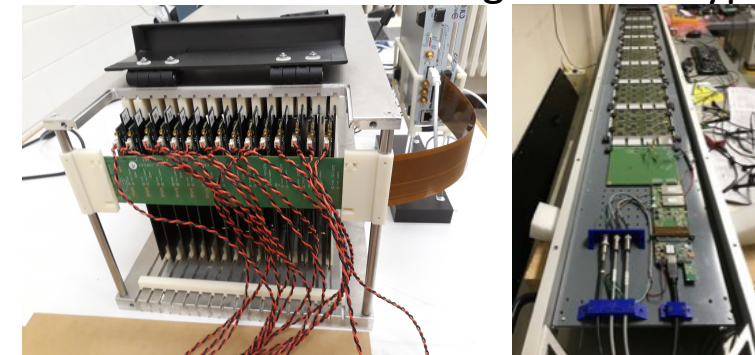
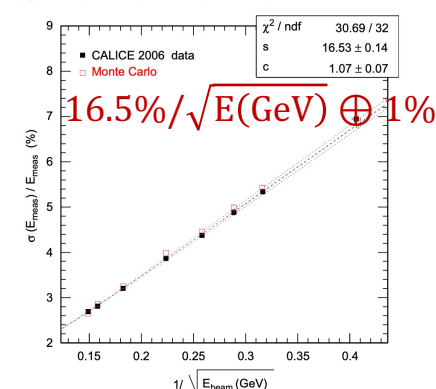
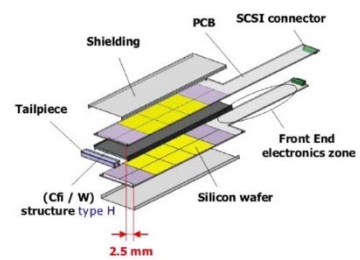
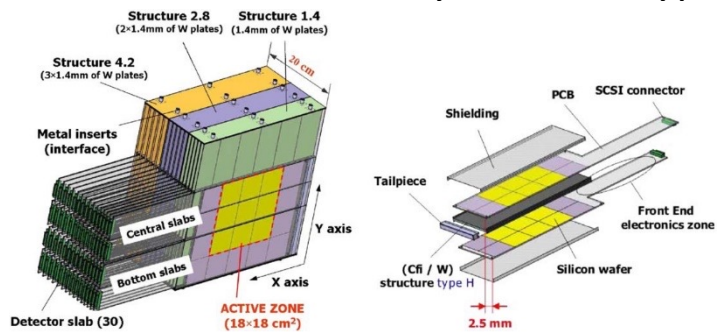
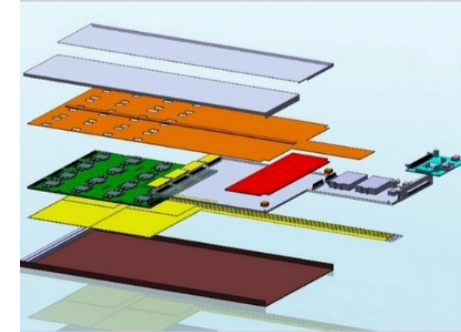

- Large area silicon sensors (pixelated) interleaved with CuW plate (compact showers)
- Baseline option in CEPC CDR: extensive Higgs physics studies
- Hardware activities in CALICE collaboration, no involvements of Chinese groups
 - Application in CMS-HGCAL project (silicon sector): many synergies

SiW-ECAL option: synergies with HGCAL

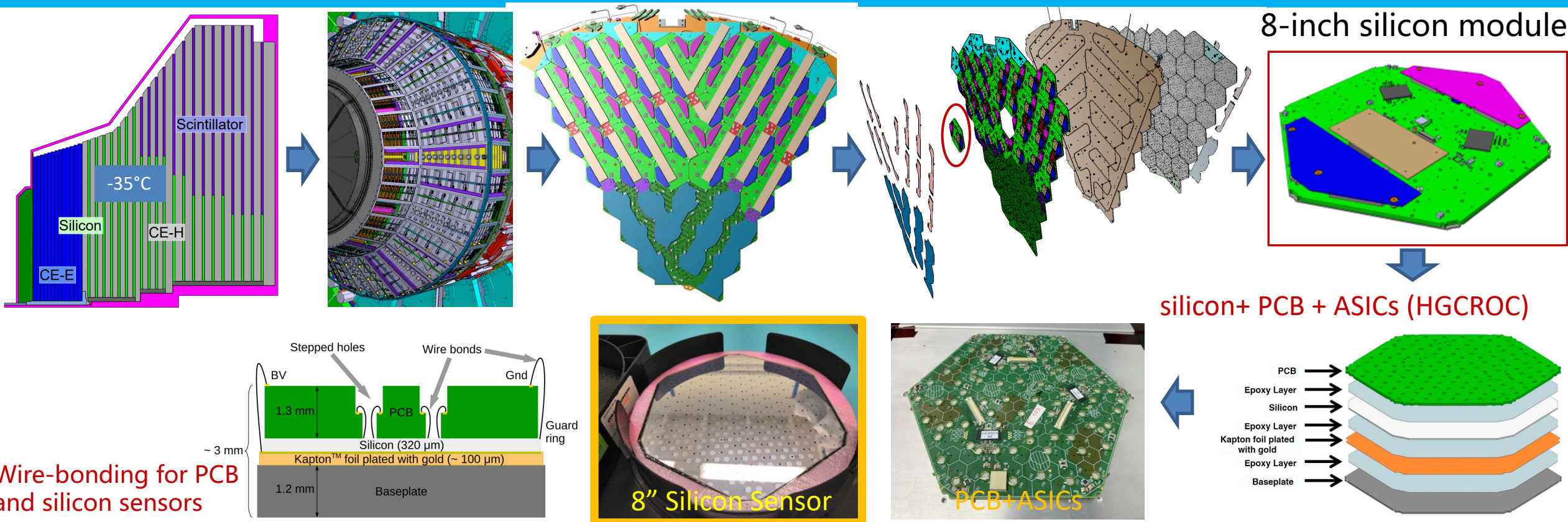

■ Established two centers at IHEP for CMS-HGCAL

- MAC (Module Assembly Center) Beijing, with 6 MACs around the world
- SQC (Sensor Quality Center) Beijing Site, with 5 SQCs around the world

ScW-ECAL option

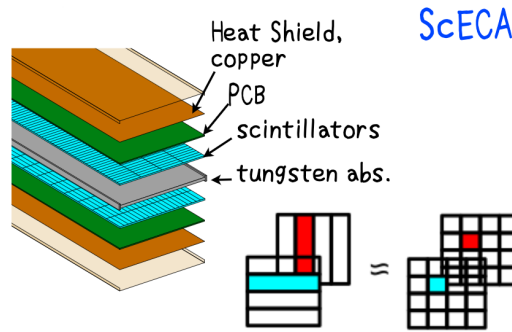
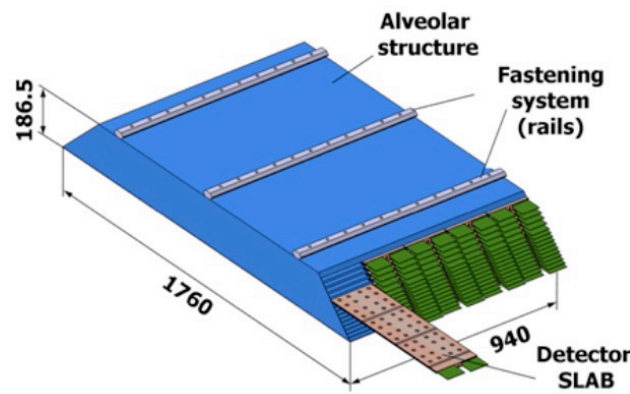
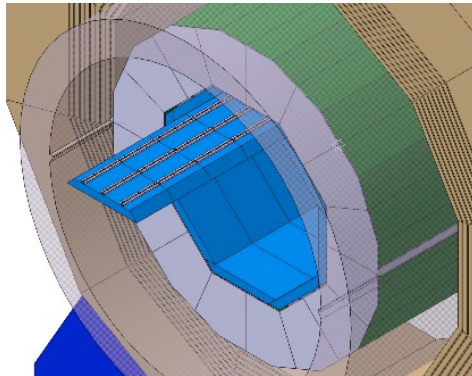

Scintillator-SiPM readout scheme

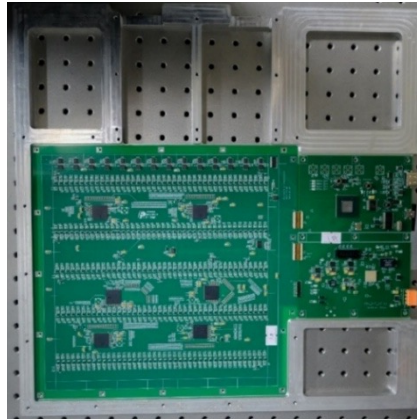
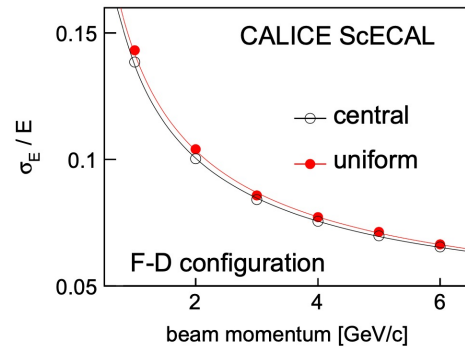
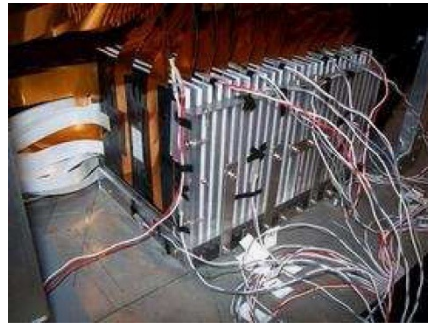
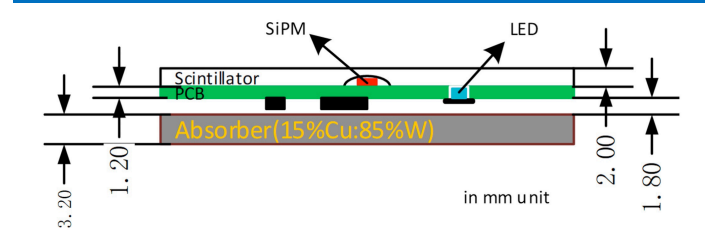

- Scintillator strips + SiPMs, interleaved with CuW plate (compact showers)
- Alternative option in CEPC CDR
- Strong involvements of Chinese groups in CALICE collaboration
 - Development of technological prototype, followed by successful beamtests at CERN

ScW-ECAL option

ScW-ECAL tech. prototype



“Super-layer” design

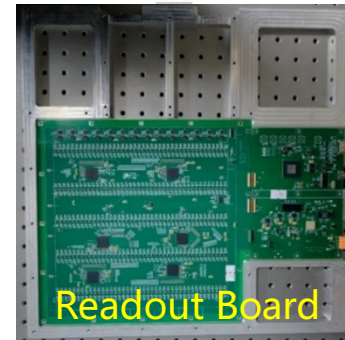
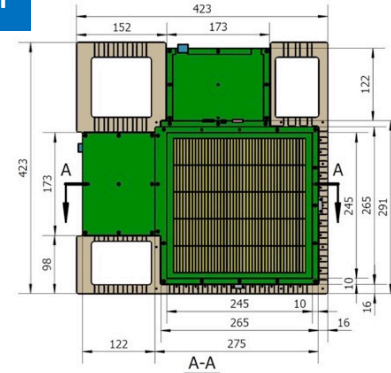
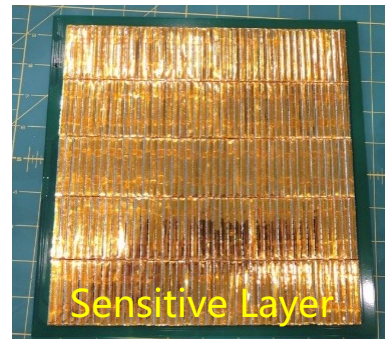
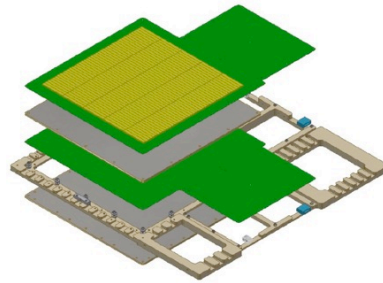

■ ScW-ECAL tech. prototype developed in 2016-2020

- (Effective) Transverse granularity of $5 \times 5 \text{ mm}^2$
- 6,720 channels, 32 longitudinal sampling layers (22X0)
- Successful beamtest campaigns at CERN in 2022-2023
 - Collected data sets with various beam particles

100GeV muon

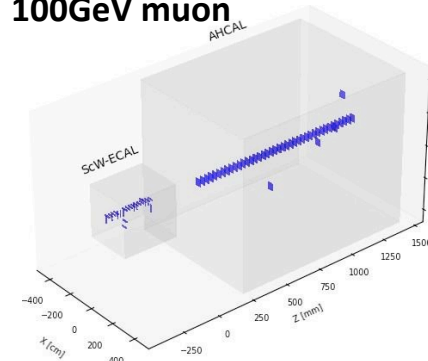

60GeV electron

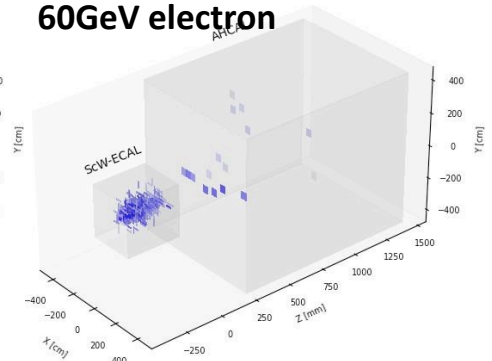

4D Crystal ECAL option

- A new option: development started since ~2020
- Compatible for PFA, Boson mass resolution (BMR) < 4%
- Optimal EM performance: $\sigma_E/E = 3\%/\sqrt{E}$
- Minimal longitudinal dead material: orthogonal arranged bars
 - 3D positioning with two-sided readout for timing

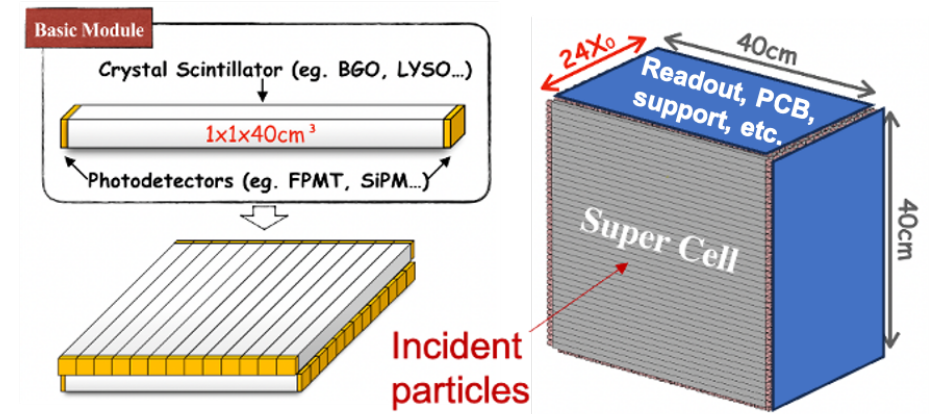

- BGO bars in 1×1×~40 cm³
- Effective granularity 1×1×2 cm³
- Modules with cracks not pointing to IP (with an inclined angle of 12 degrees)

CEPC Reference detector

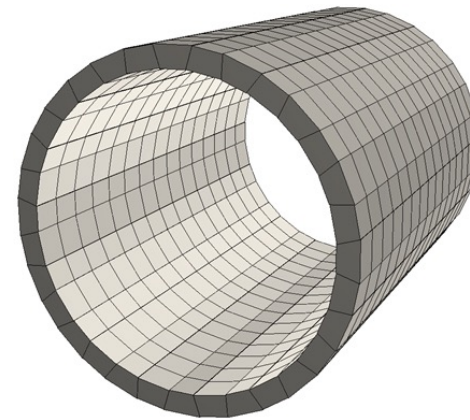
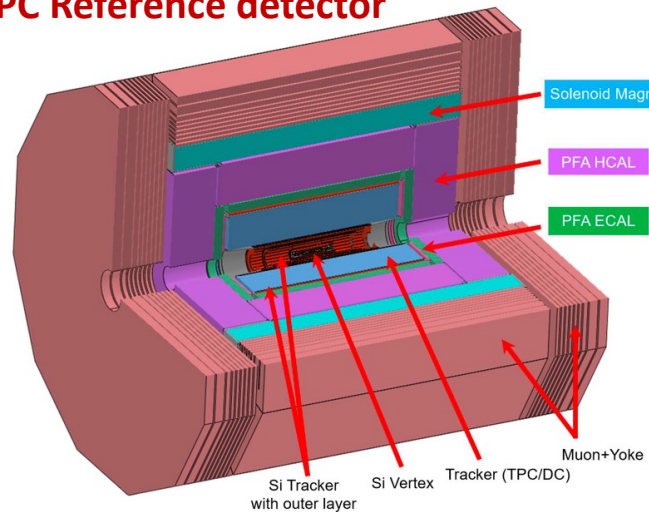

32-side polygon, depth 24 X₀
28 layers in longitudinal

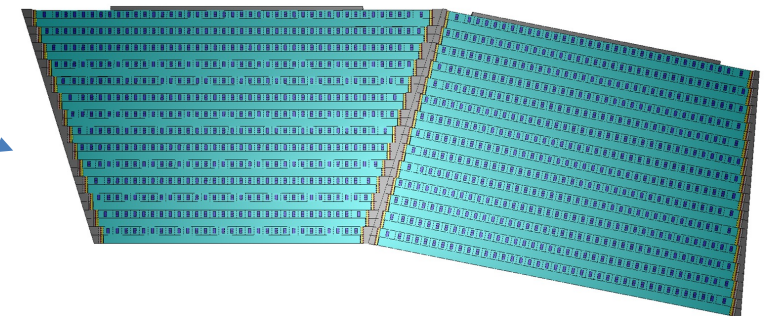

Technical options: comparison and selection

Technical Option	Silicon-Tungsten ECAL	Scintillator-Tungsten ECAL	Crystal ECAL
EM energy resolution	$\sigma_E/E = 17\%/\sqrt{E(GeV)}$	$\sigma_E/E = 13\%/\sqrt{E(GeV)}$	$\sigma_E/E = 3\%/\sqrt{E(GeV)}$
Particle-Flow Algorithm(s)	Arbor; Pandora	Arbor; Pandora	New dedicated PFA (ongoing developments)
Jet Performance (with a full detector)	Boson Mass Resolution (BMR) <4%		
Technical Readiness Level (prototypes, beamtests)	Physics Prototype (2006-2010) Technological Prototype (2011-now)	Physics Prototype (2007) Technological Prototype (2016 - 2021)	First Physics Prototype (2022-2024)
Novelty Level	ILD (proposed in ILC TDR 2013), followed by several detector concepts: CLICdp CDR (2012) , CEPC CDR (2018) , FCC CDR (2019)		A completely new concept proposed by the CEPC team

Option selection

- *Crystal ECAL*, as a novel option, shows significantly better EM performance

Selected as a baseline option for the CEPC reference detector

Main Technical Challenges

■ High granularity: ~1M channels

- Multi-channel ASIC embedded in readout boards
- Hermetic design: minimum space for mechanics and services (cooling, cabling)
- Low power consumption, given material budget and hermicity
- Mass production capability and scalability to a final detector

■ Beam-induced backgrounds

- Data throughput, pile-ups (events + backgrounds)

■ Irradiation damages

- SiPM, crystal: monitoring, calibration, annealing
- ASIC, FPGA: radiation tolerant

■ In-situ calibration system (on-detector)

- SiPM, crystal due to irradiation (instantaneous, long-term), temperature

Crystal ECAL: specifications

Key Parameters	Value	Remarks
MIP light yield	~200 p.e./MIP	Ensure EM resolution $\sim 3\%/\sqrt{E}$
Energy threshold	0.1 MIP	Balance between S/N and dynamic range
Crystal non-uniformity	< 1%	Along the crystal length and between crystals
Dynamic range	0.1~3000 MIPs / channel	Maximum energy deposition with 360 GeV Bhabha
Timing resolution	~500 ps @ 1 MIP	Bunch crossing ID; clustering and hadron performance
Temperature stability	Stable at 0.05°C	Reference from CMS ECAL; validation with beamtest

Detector requirements

- Moderate MIP light yield
- Good uniformity
- Optimal time resolution
- Large dynamic range
- Moderate S/N ratio

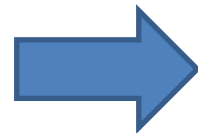

Hardware activities: addressing crucial issues

- SiPM response linearity
- Uniformity of long crystal bar
- Time resolution: different crystal dimensions
- Dynamic range of electronics
- Energy response of crystal module

R&D efforts and results: MIP response, uniformity

- Geant4 full simulation with digitization: shower studies, requirements
- Dedicated setup with radioactive sources for energy resolution, response uniformity

MIP response: >200 p.e./MIP $\rightarrow \sigma_E/E = 3\%/\sqrt{E}$
Energy threshold: 0.1 MIP

Light yield v.s. energy resolution

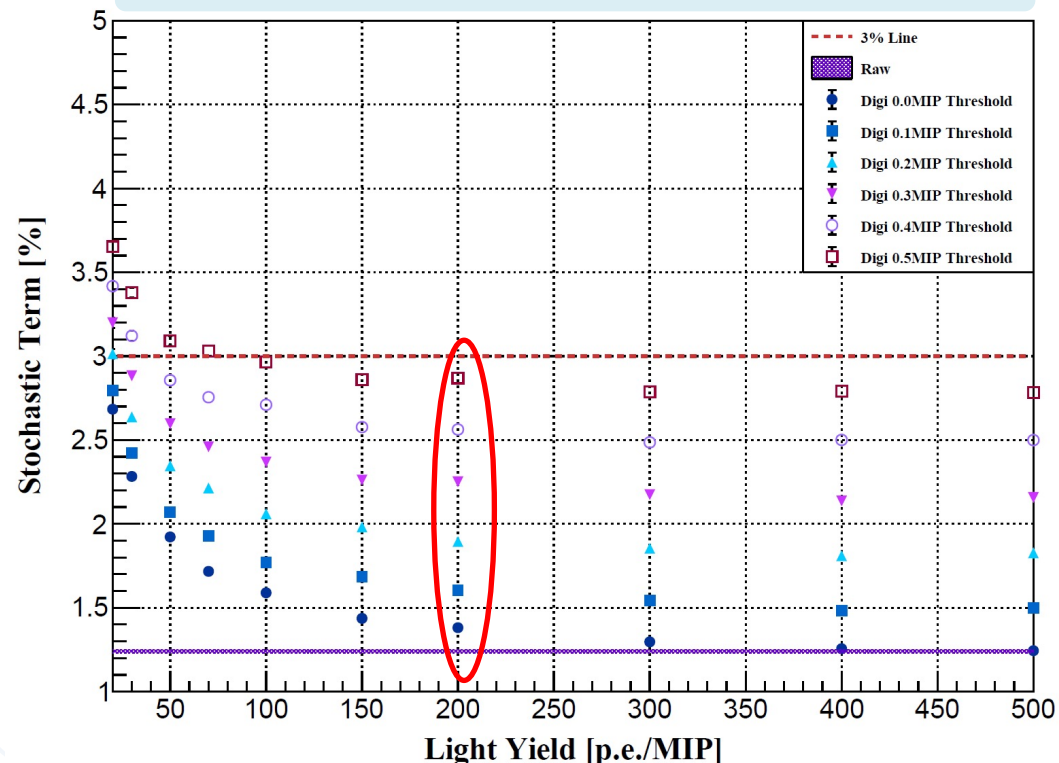

Uniformity along one 40 cm crystal bar: $\sim 2.5\%$
- Can be further improved by calibration system

Response uniformity along bar

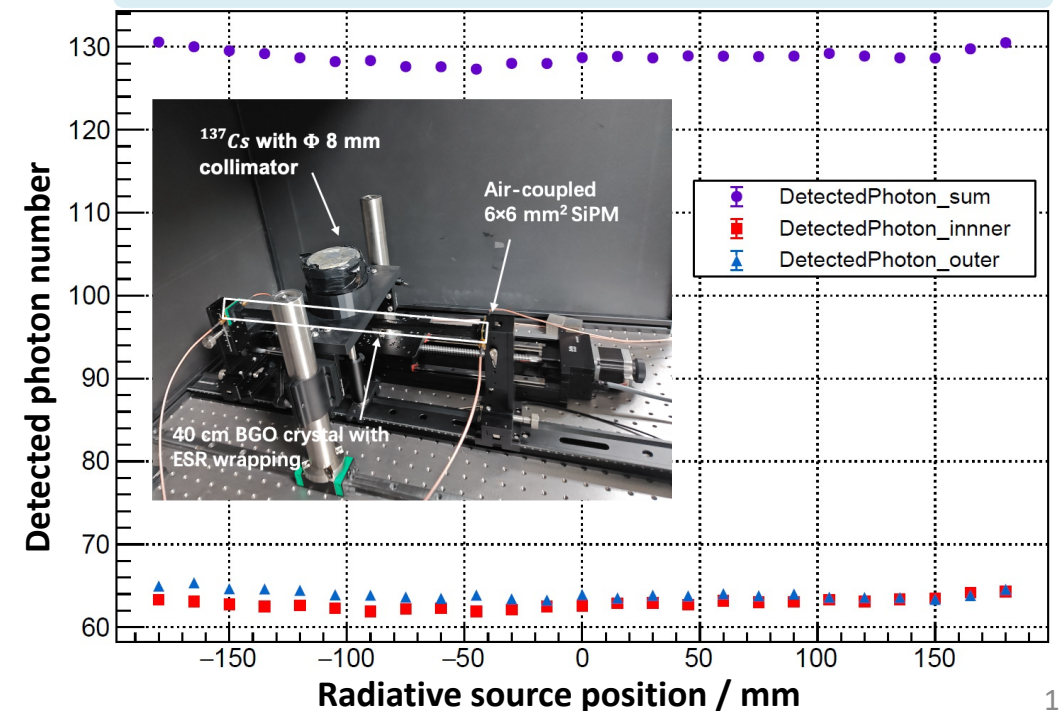

R&D efforts and results: dynamic range

- Simulation of high energy electrons: maximum energy per crystal
- Test-stand with pico-second laser: SiPM non-linearity effects (with various pixel pitches)
- Beamtest of crystal-SiPM units with a state-of-art chip: dynamic range of both SiPM and ASIC

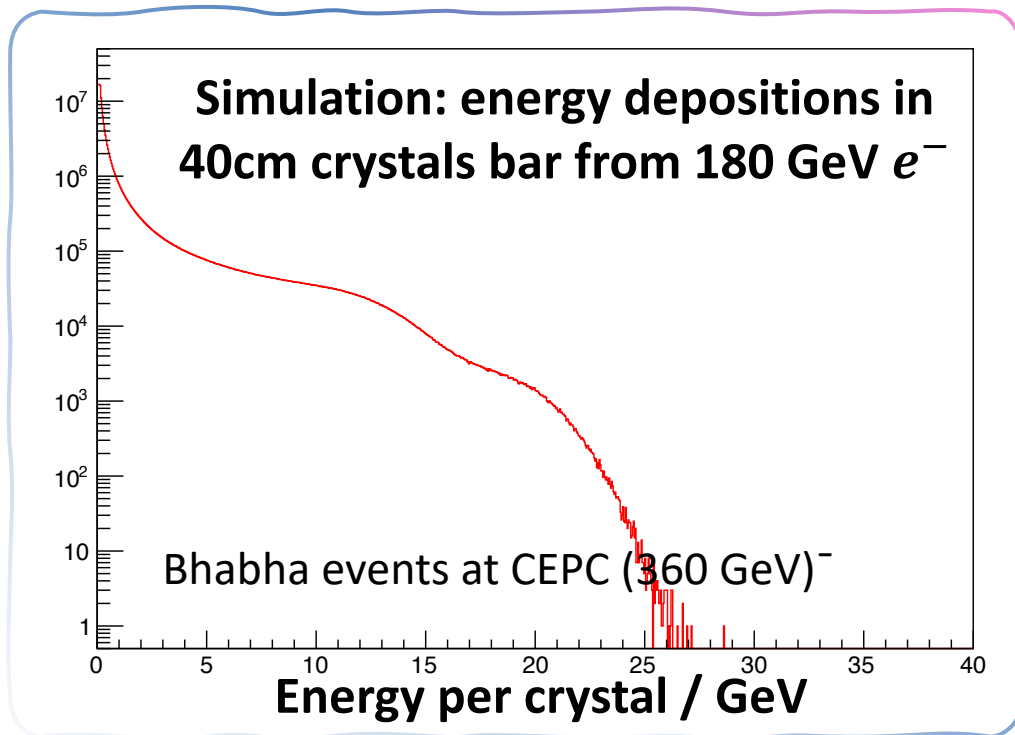

~30 GeV as max. energy deposition per crystal bar

Laser system for SiPM non-linearity studies Chip dynamic range: ~33000 p.e. for 25um SiPM

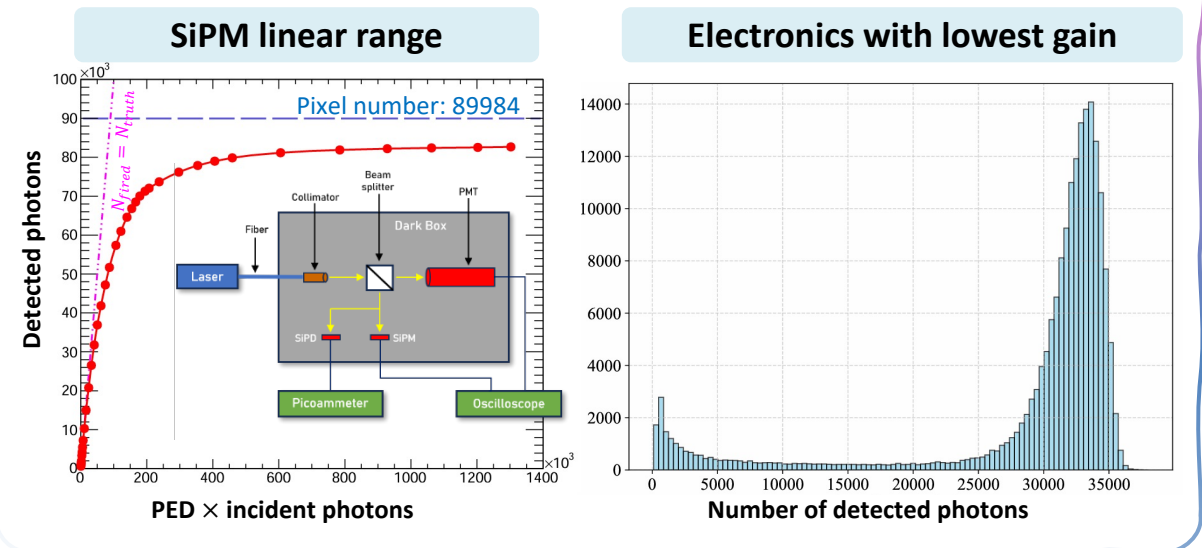

2023 DESY beamtest: crystal-SiPM units and a state-of-art front-end chip with EM showers induced by 5 GeV electrons

R&D efforts and results: timing studies

- Dedicated beamtests for timing studies with MIP and EM showers

Timing performance within EM showers

- 5GeV e^- beam to test 40cm BGO bar with 25 μm SiPM
- **~200 ps within EM showers** (>12 MIPs)

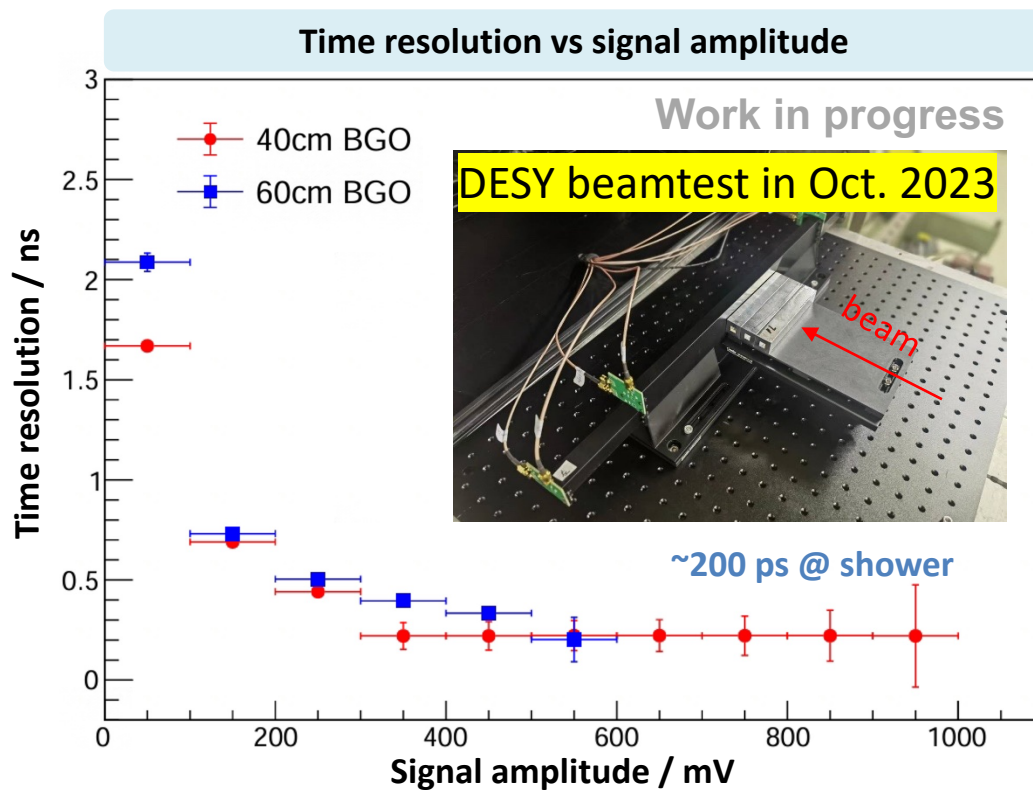

Timing performance with MIP-like particles

- 10 GeV π^- beam to scan one 40cm BGO bar along its length
- 1-MIP timing resolution: **735 ps** for 2 ends \rightarrow **520 ps** single end

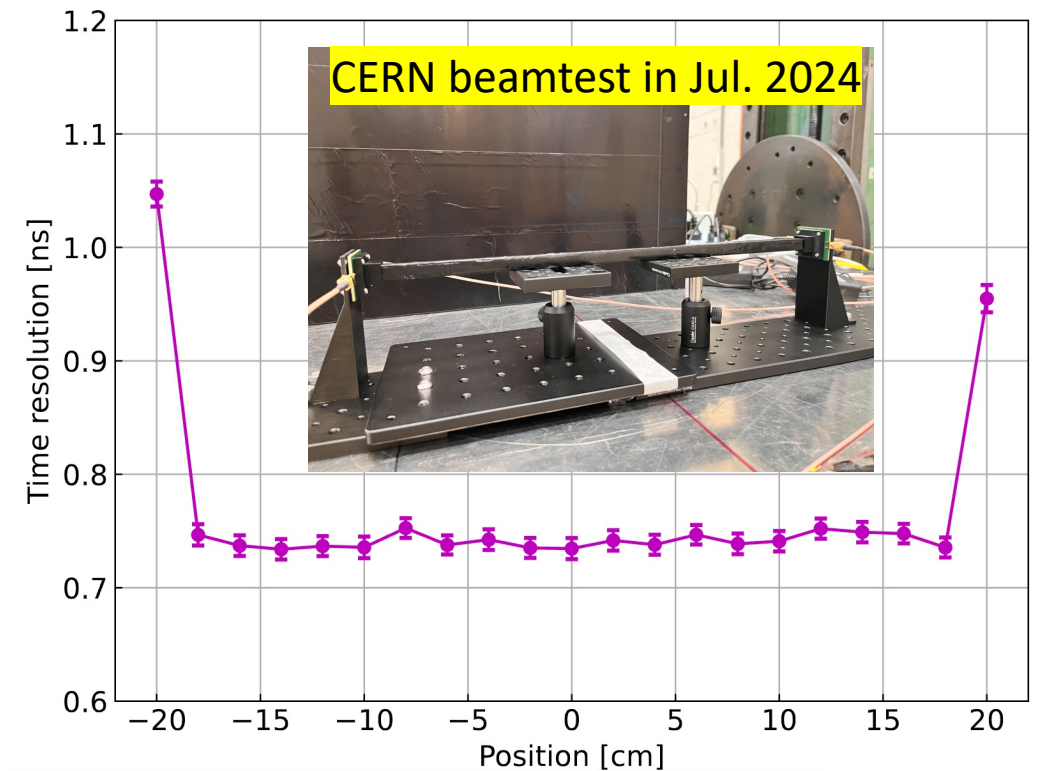

4D Crystal Calorimeter: First Physics Prototype

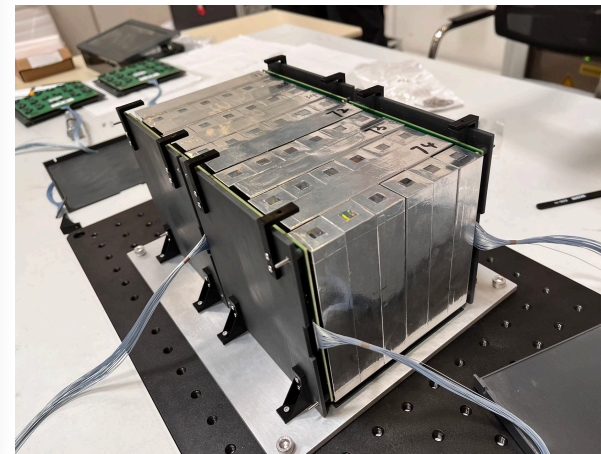
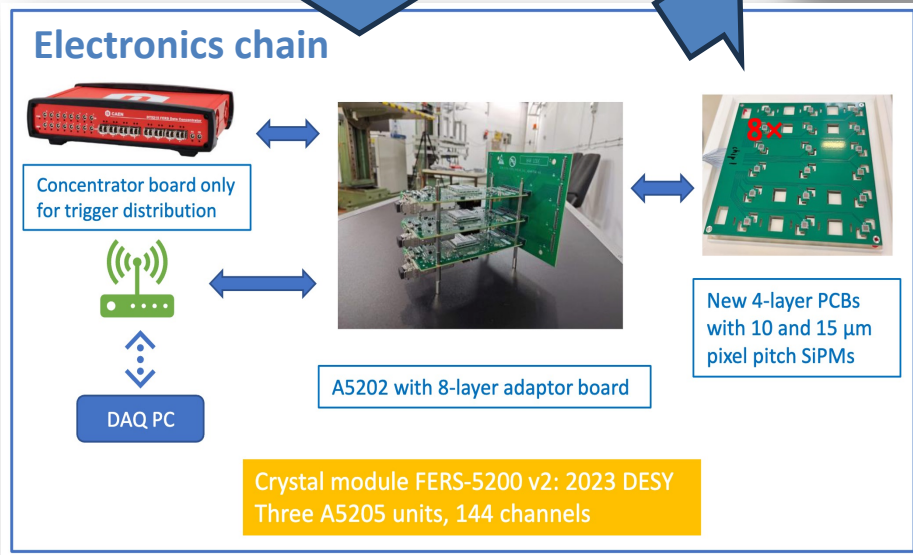
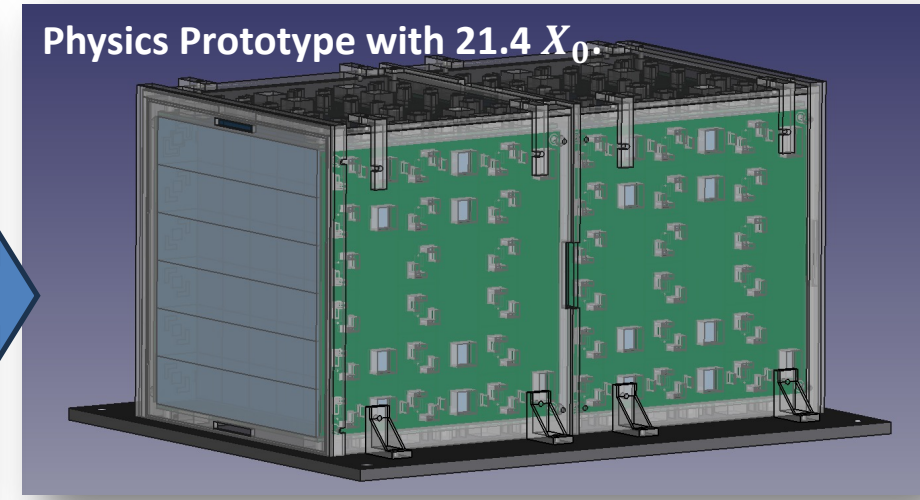
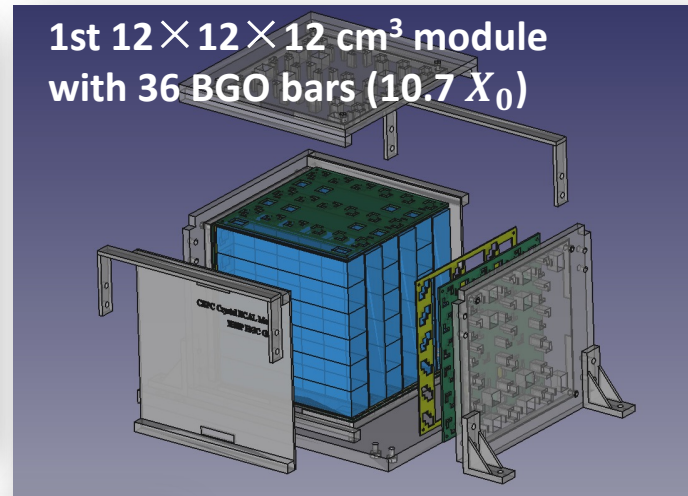
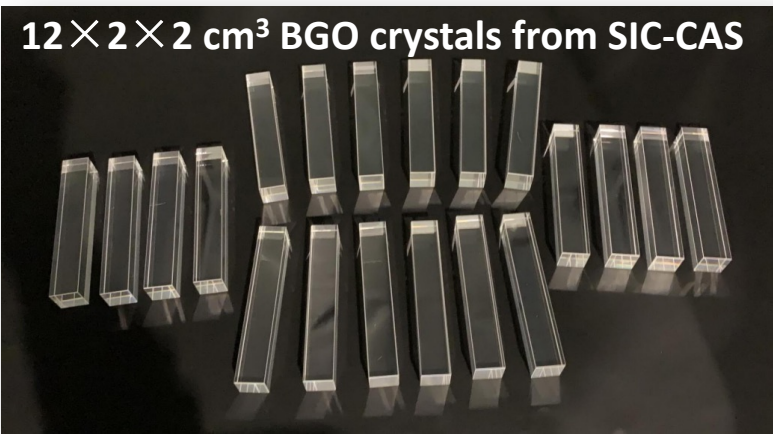

First crystal calorimeter prototype

- Successfully developed in 2021-23
- With commercial ASICs

Major motivations

- Critical issues at system integration
- EM performance in system level
- Validation of simulation and digitization with beamtest data

Custom-made readout boards (144-ch), equipped with 6 ASICs (CITIROC-1A) → Custom-made ASIC in planning

Beam tests: 4D Crystal Calorimeter Prototype

2023 CERN beam test at PS-T9

- Successful system commissioning
- Clear MIP signals for all channels

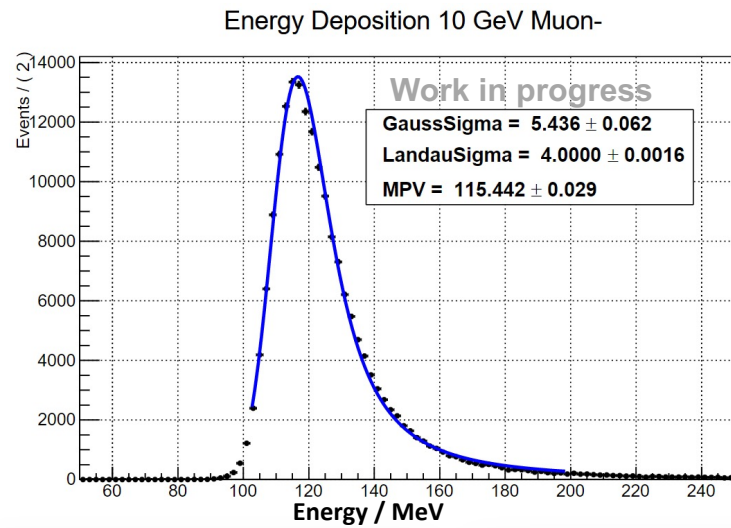

2024 CERN beam test at PS-T9: finished in July 10th

- Promising EM resolution with 1-5 GeV/c e^- beam
- Data analysis is still ongoing: detailed calibrations, shower profiles

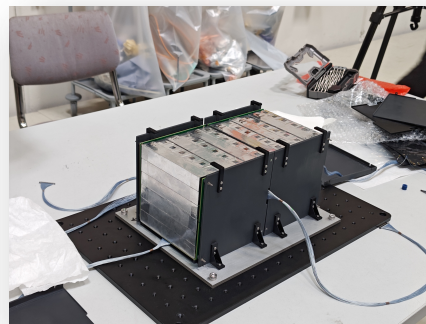
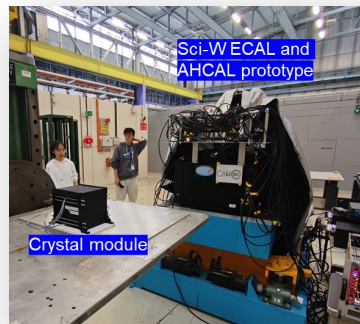
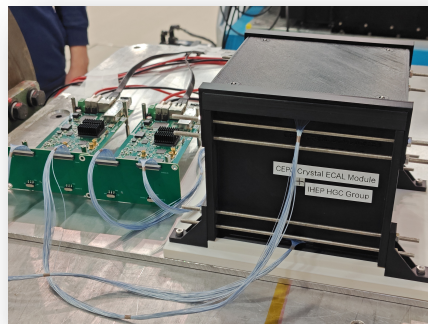
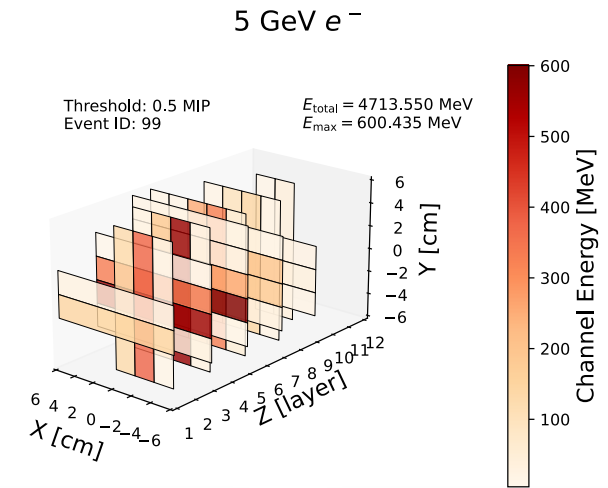
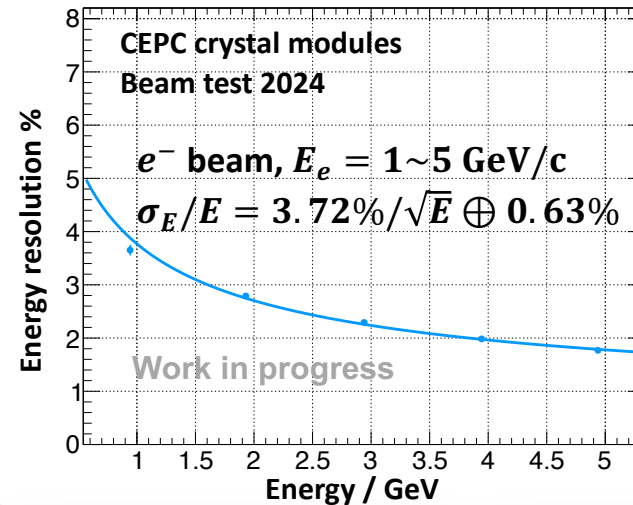

Beam tests: 4D Crystal Calorimeter Prototype

2023 CERN beam test at PS-T9

- Successful system commissioning
- Clear MIP signals for all channels

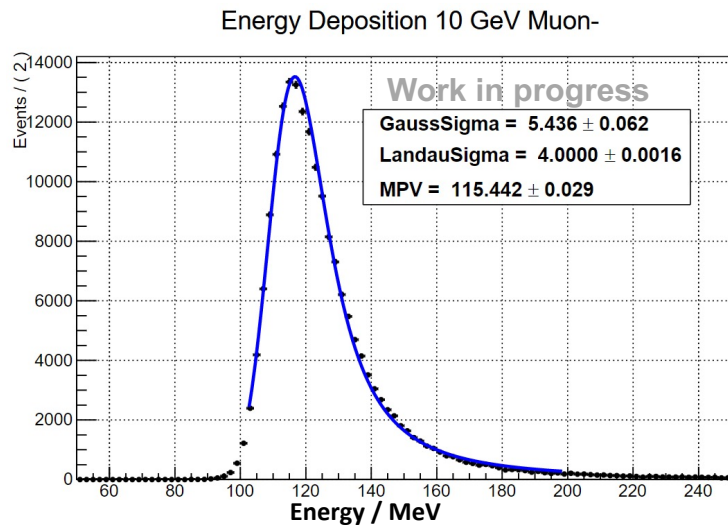

2024 CERN beam test at PS-T9: finished in July 10th

- Promising EM resolution with 1-5 GeV/c e^- beam
- Data analysis is still ongoing: detailed calibrations, shower profiles

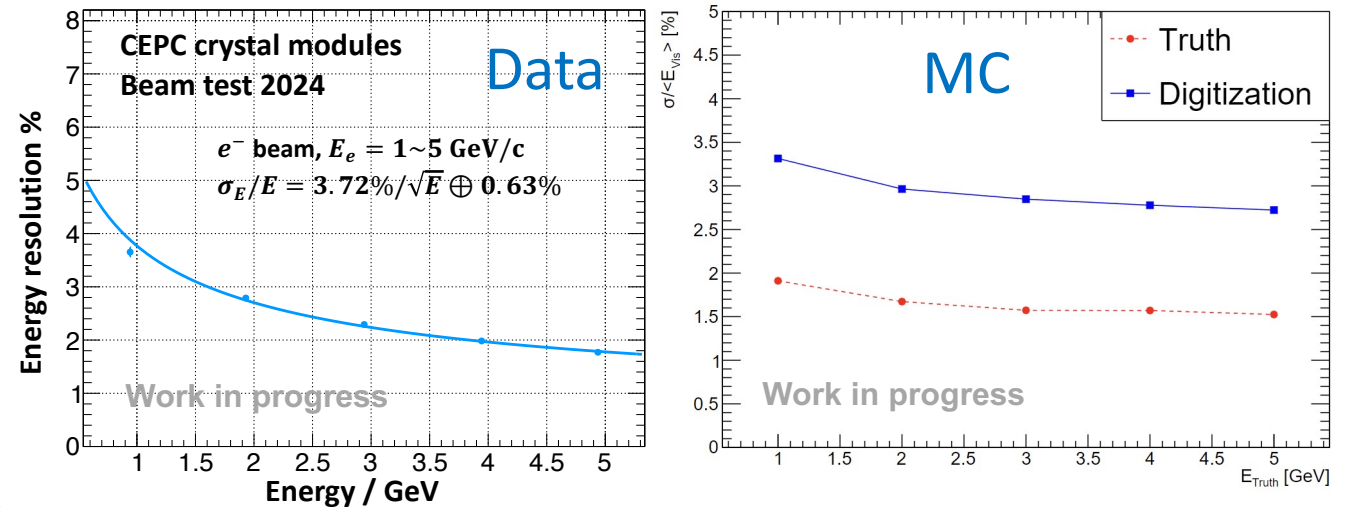

Possible reasons for preliminary 3.7% EM resolution

- Limitations of commercial ASIC: pedestal shifts (stability), High Gain and Low Gain switch
- *Gaussian* fitting to reconstructed energy (asymmetric distribution)

Ongoing investigations

- Implementations of ASIC into simulation and digitisation: ASIC pedestals, HG/LG switch
- *Crystal Ball* function: better description of lossy processes (low energy)

Crystal ECAL: impacts of temperature stability

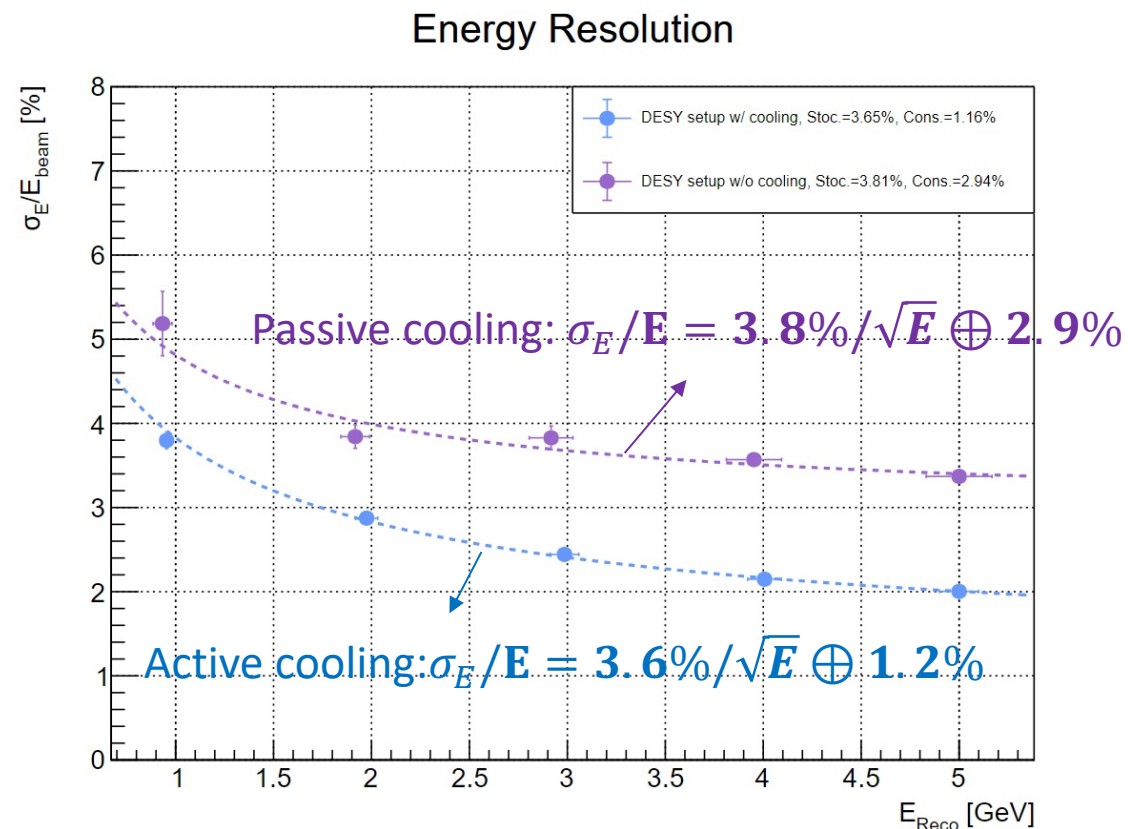

Temperature stability is crucial to crystal ECAL

- Significant impact to constant term of EM resolution
- Specification on stability of ± 0.05 °C is validated with beamtest data

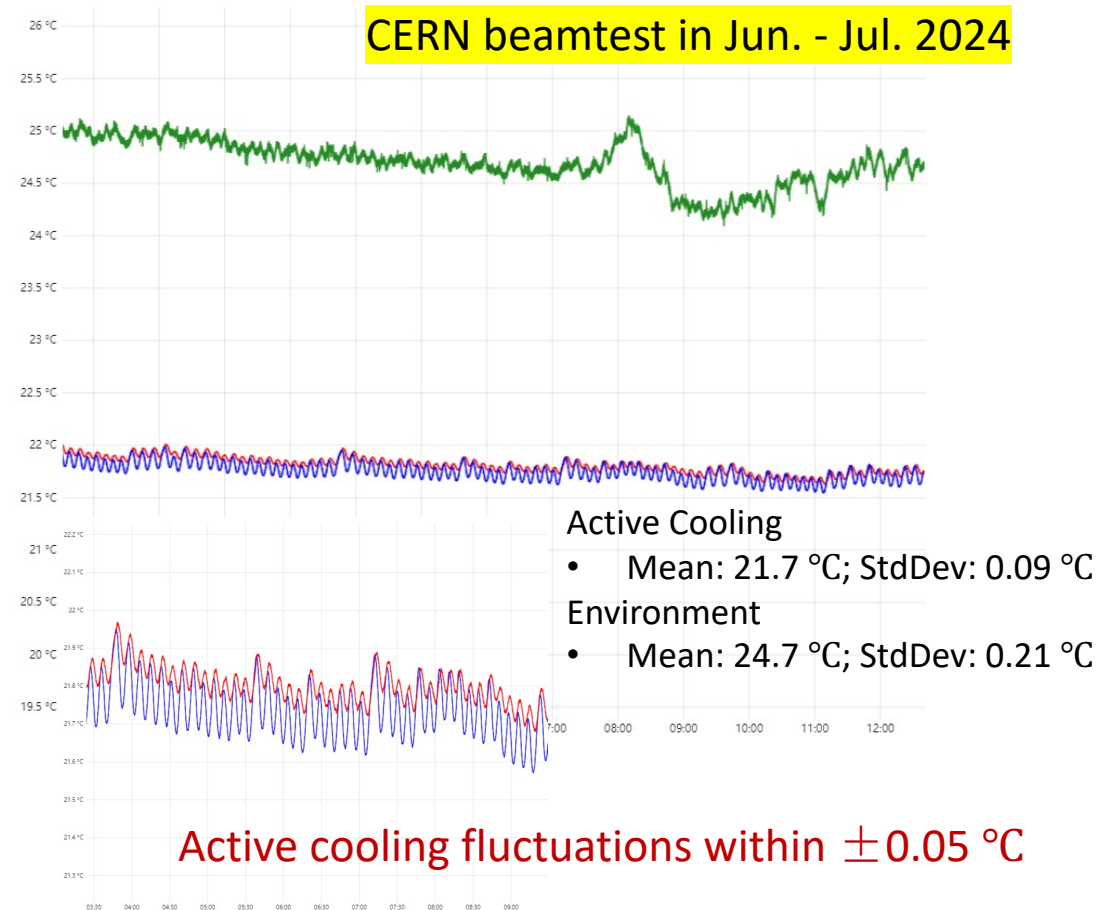

ECAL mechanics design

- A first design of ECAL mechanics with active cooling

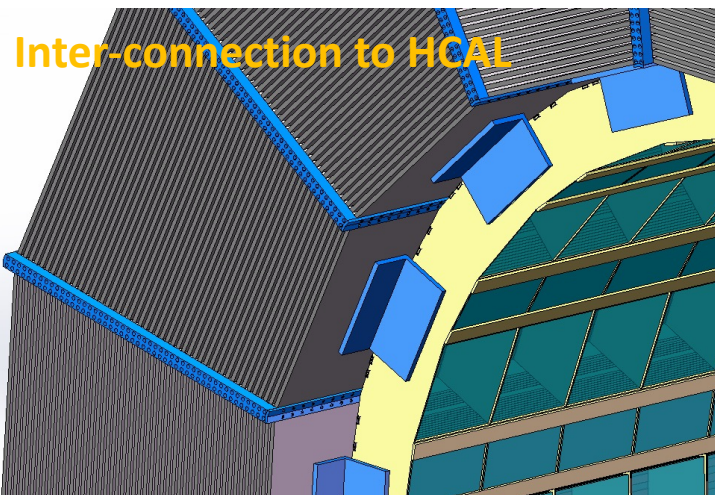

Barrel ECAL parameters

Parameter	Value / mm
Inner radius	1900
Outer radius	2200
Length	5900
Crystal length	~ 400
# Modules in $r - \phi$	32
# Modules in Z	15
ϕ Projectivity tilt	12°
# Layers	28

Barrel ECAL design

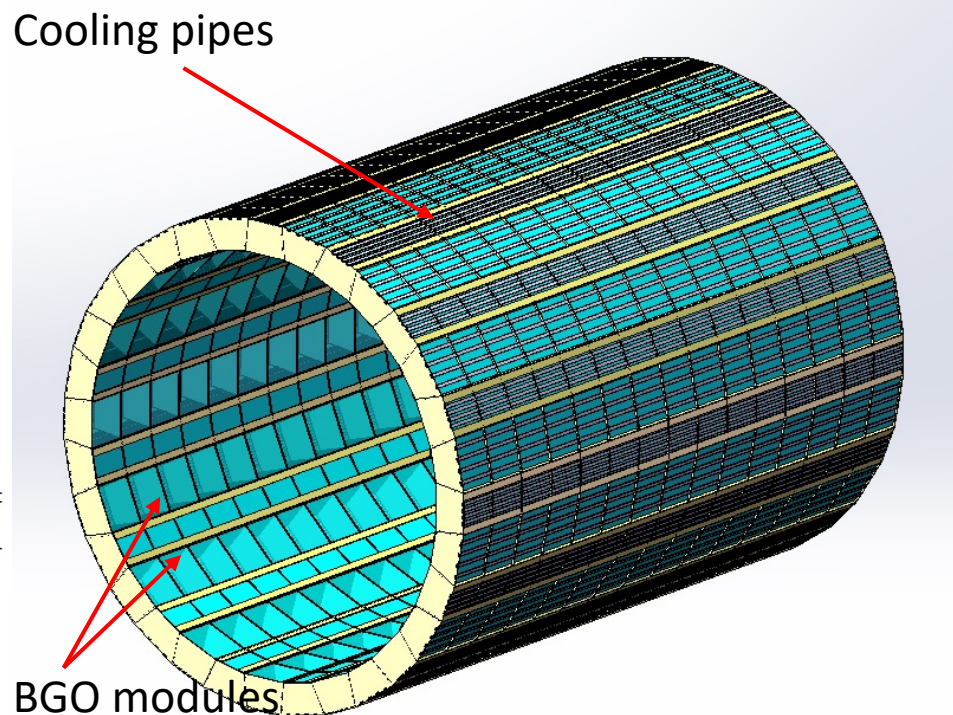

Endcap ECAL design

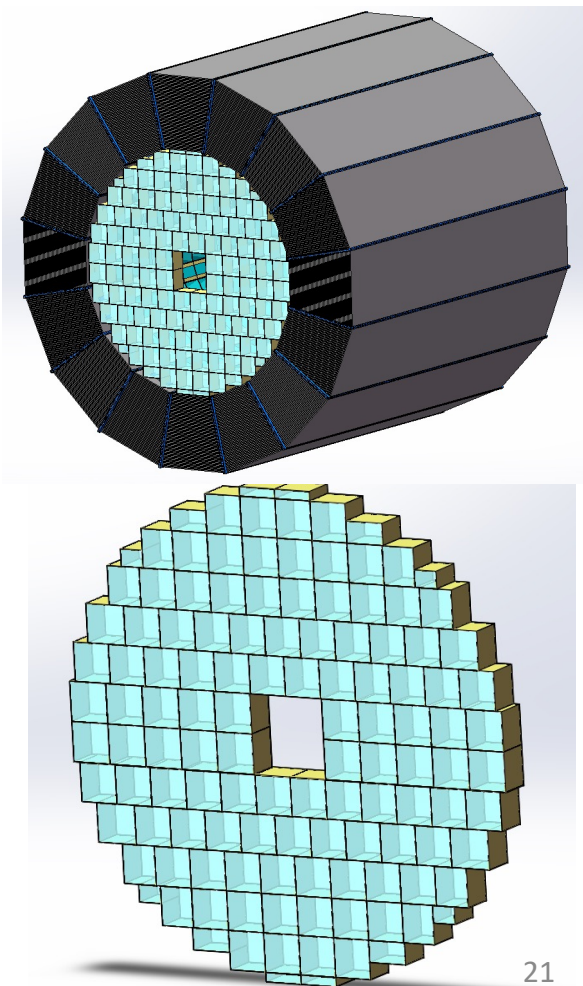

- Support structure is based on Carbon-Finbers for BGO modules (in cyan)

ECAL mechanics design: FEA simulation

- FEA simulation studies on ECAL mechanics (ongoing): further iterations + validation

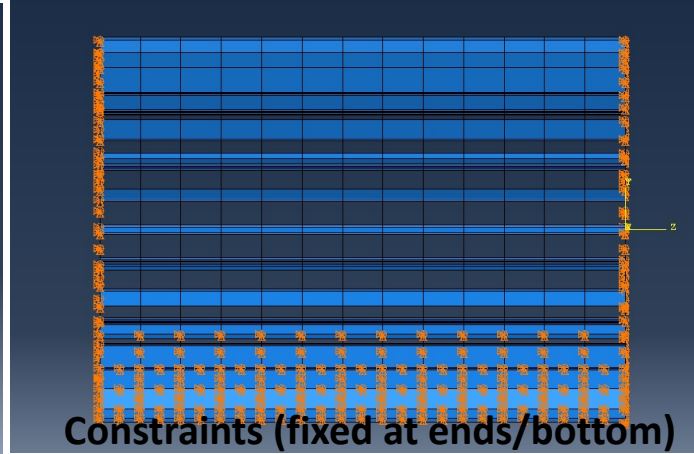
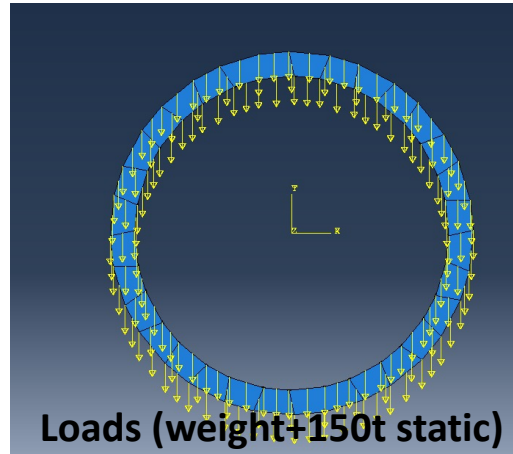
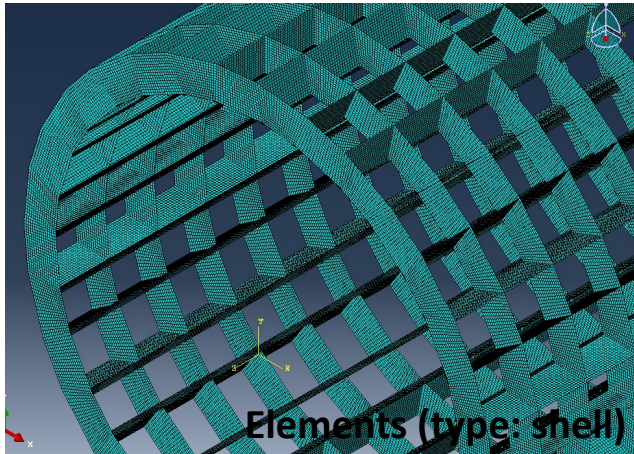

- **Material** :T700 reinforced epoxy resin.
- **TSAIW=0.64** (When **TSAIW=1**, material begins to fail)
- **Safety factor** of the structure is $1/0.64=1.56$

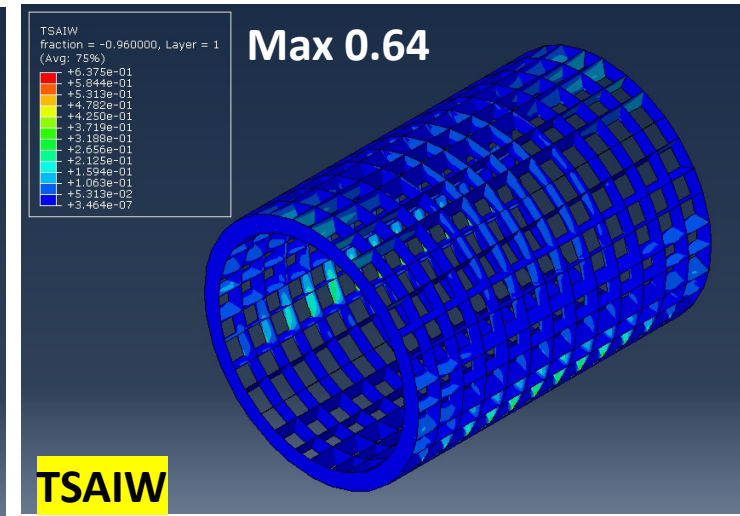
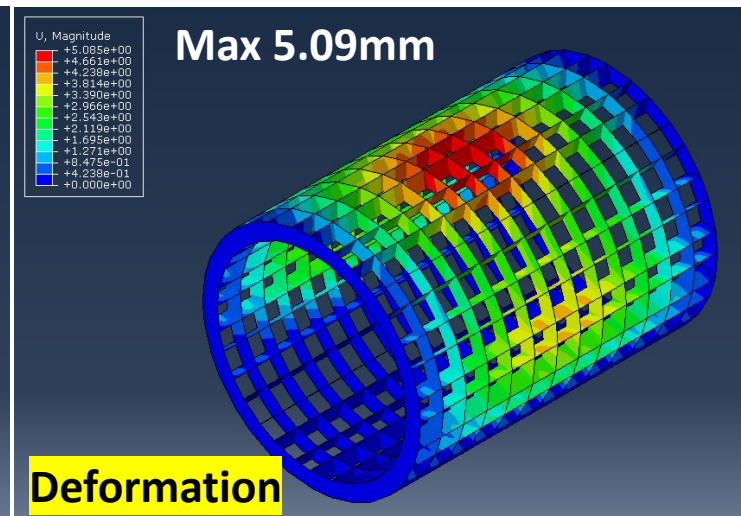
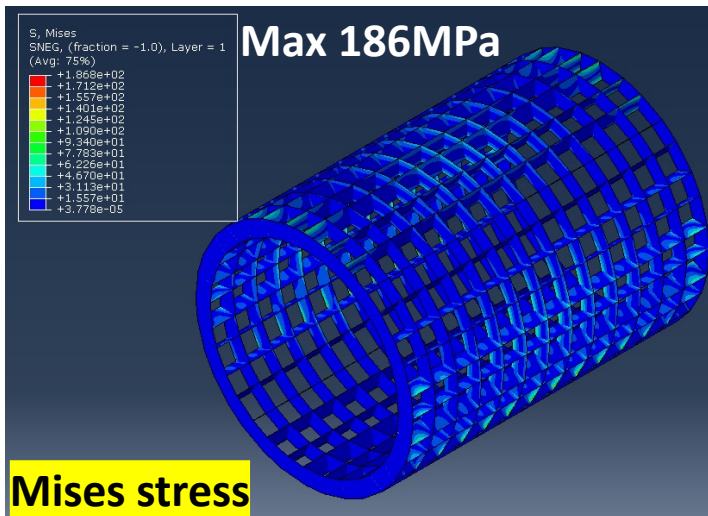

(Failure parameters of composite materials)

ECAL cooling system

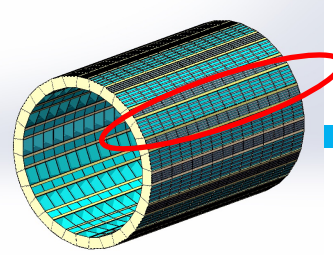

Cooling for 1/32 barrel module
42W for each module (**15mW/ch**)

■ FEA simulation studies on ECAL cooling

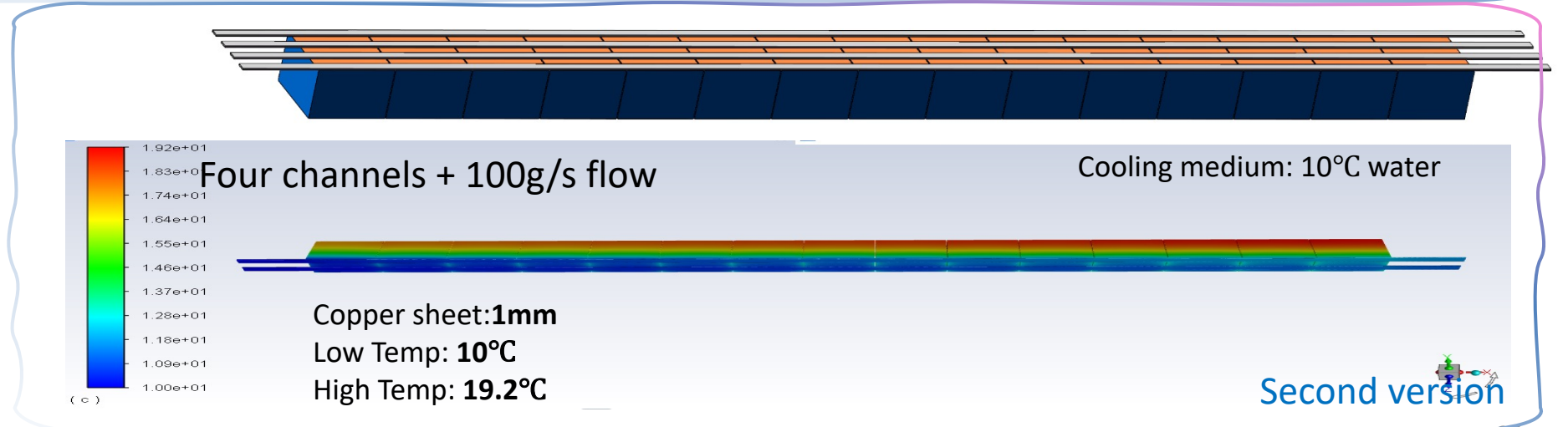
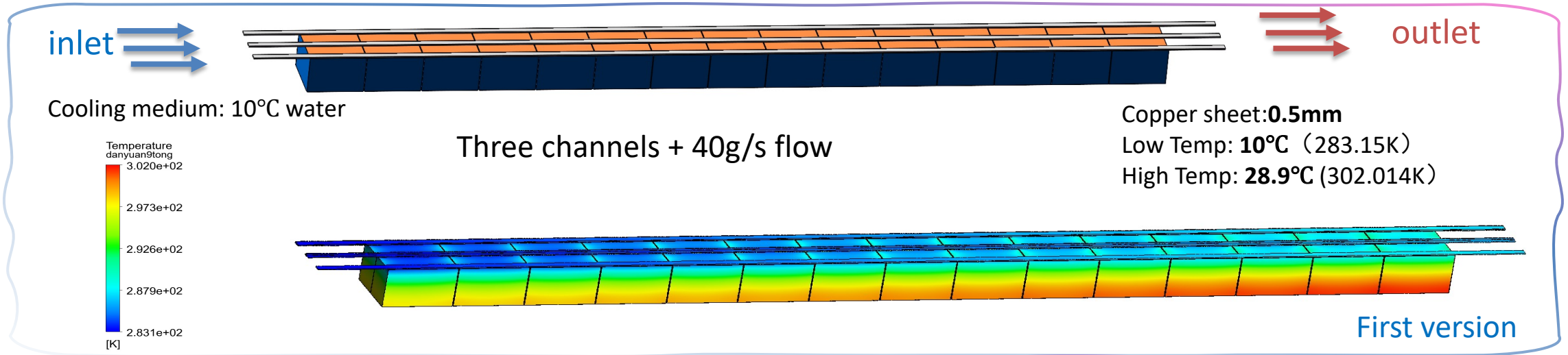

Temperature requirements:
 Gradient within $\pm 1.5^\circ\text{C}$
 Stability within $\pm 0.05^\circ\text{C}$

ECAL module integration

- FEA simulation studies on ECAL mechanics (ongoing): further iterations + validation

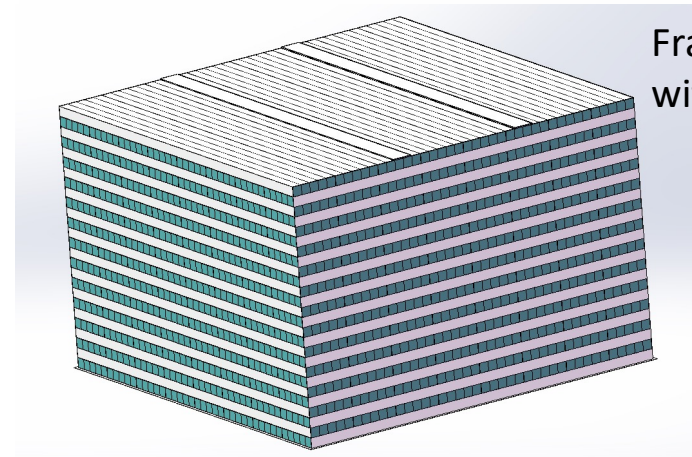
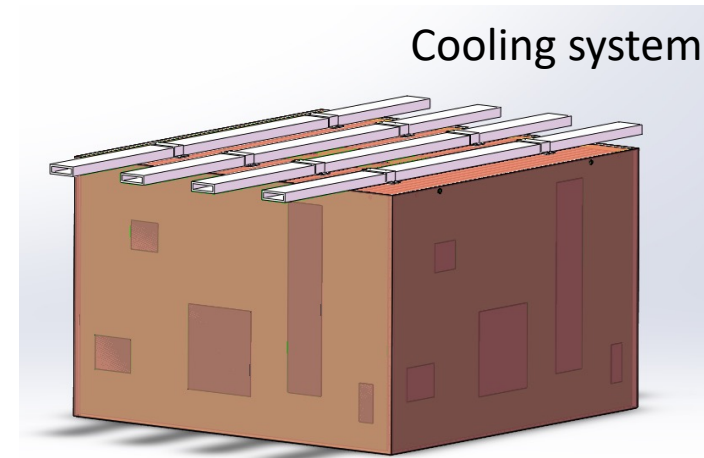
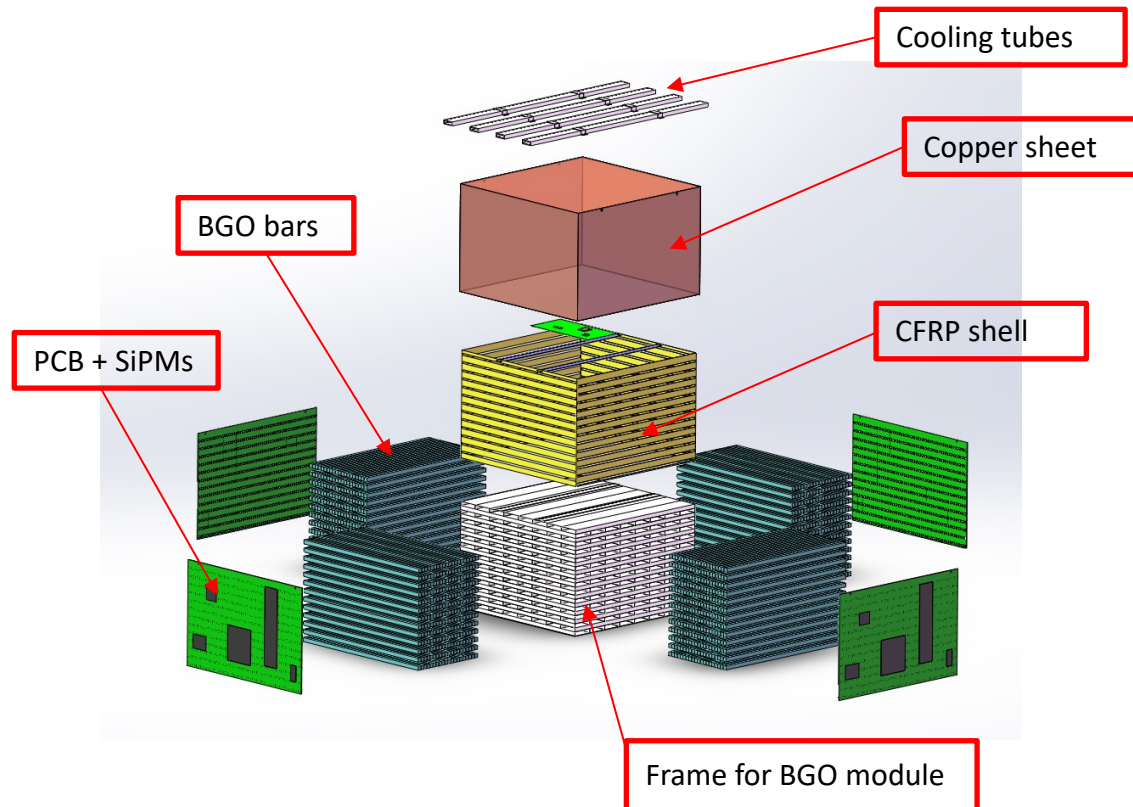

Frame is made of CFRP with 5 BGO bars in 1 cell.

Readout electronics for ECAL

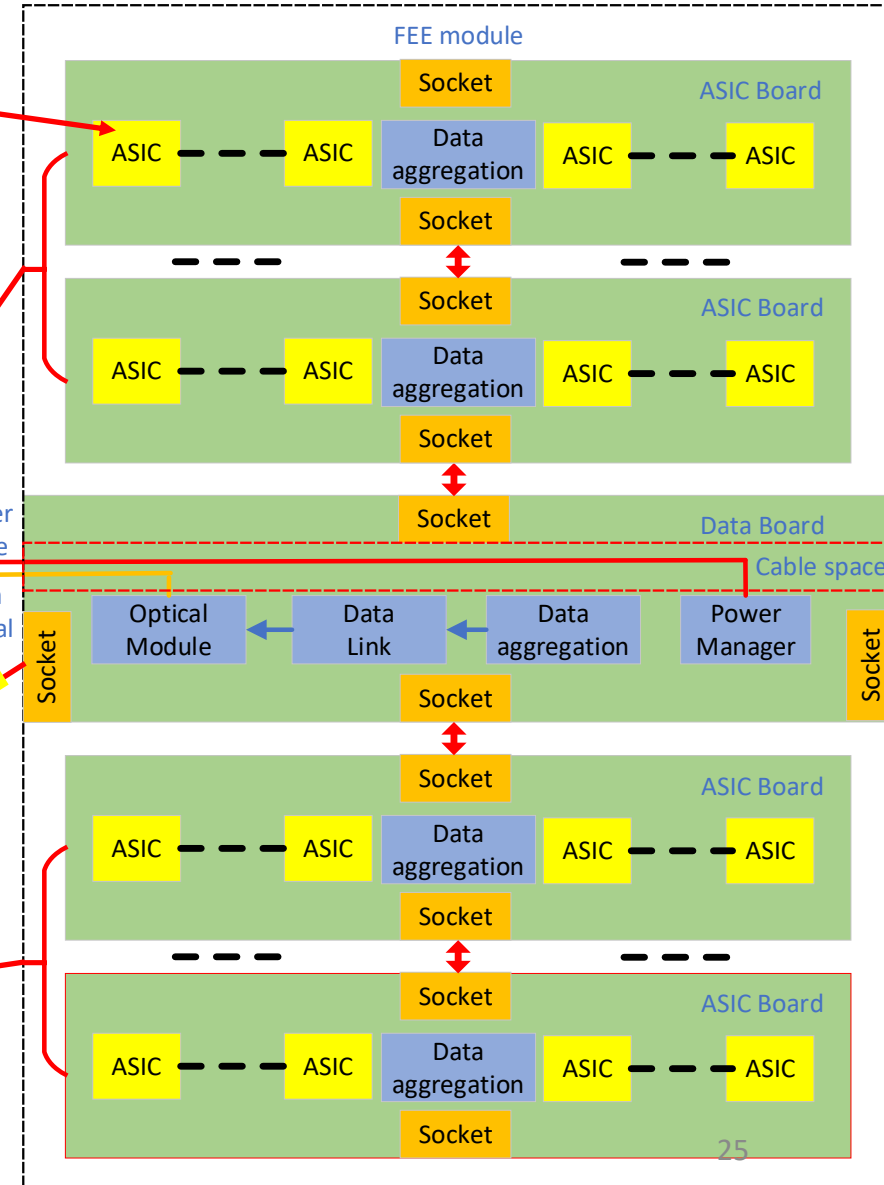
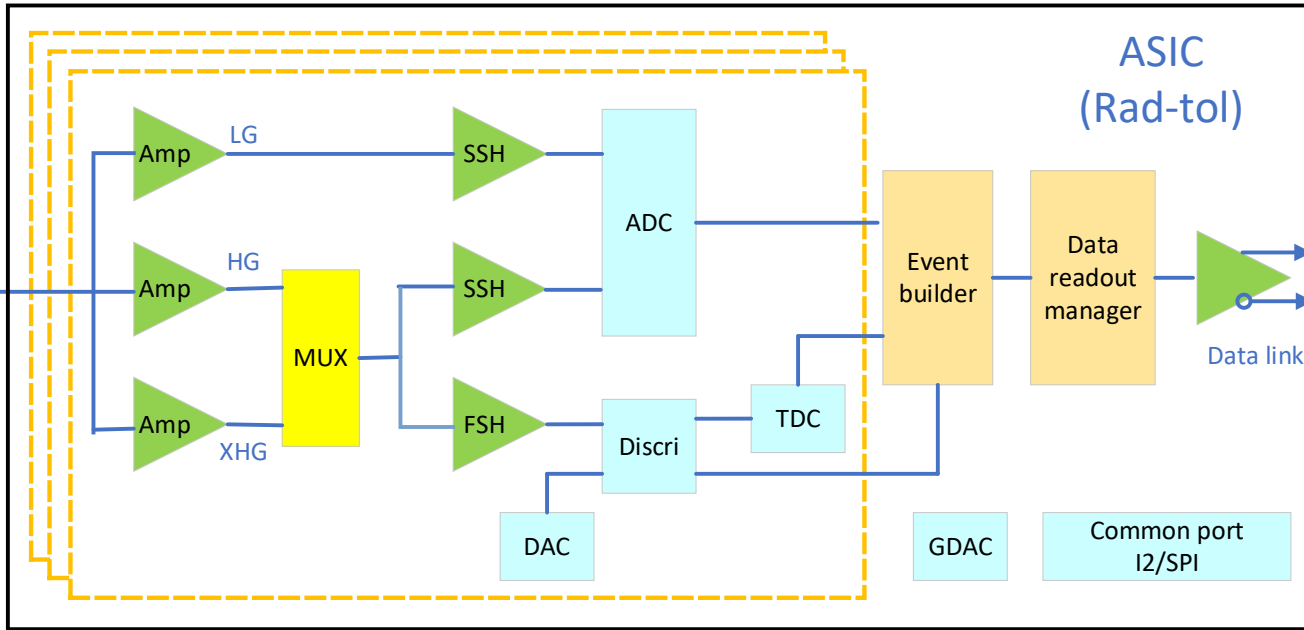

- For different options, FEE module can be one PCB or multiple PCBs
- PCB dimensions: flexible to different options
- 15mW/ch (estimate)

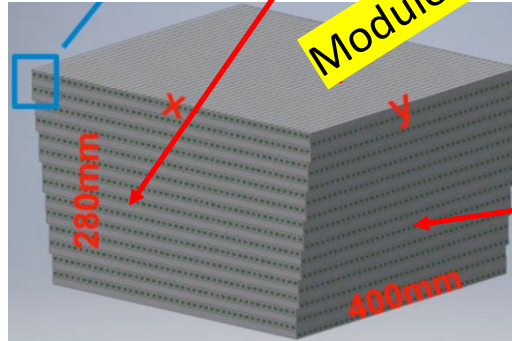
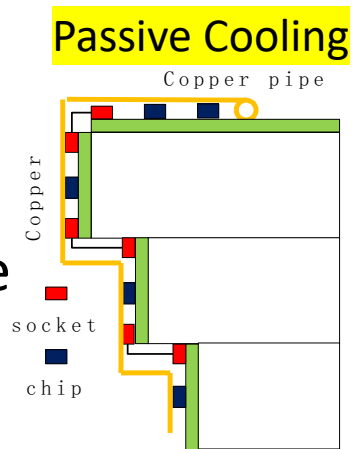

Module Lateral Part
Module Top Part

Beam-induced backgrounds: simulation studies

Hit map of 1st layer in crystal barrel ECAL

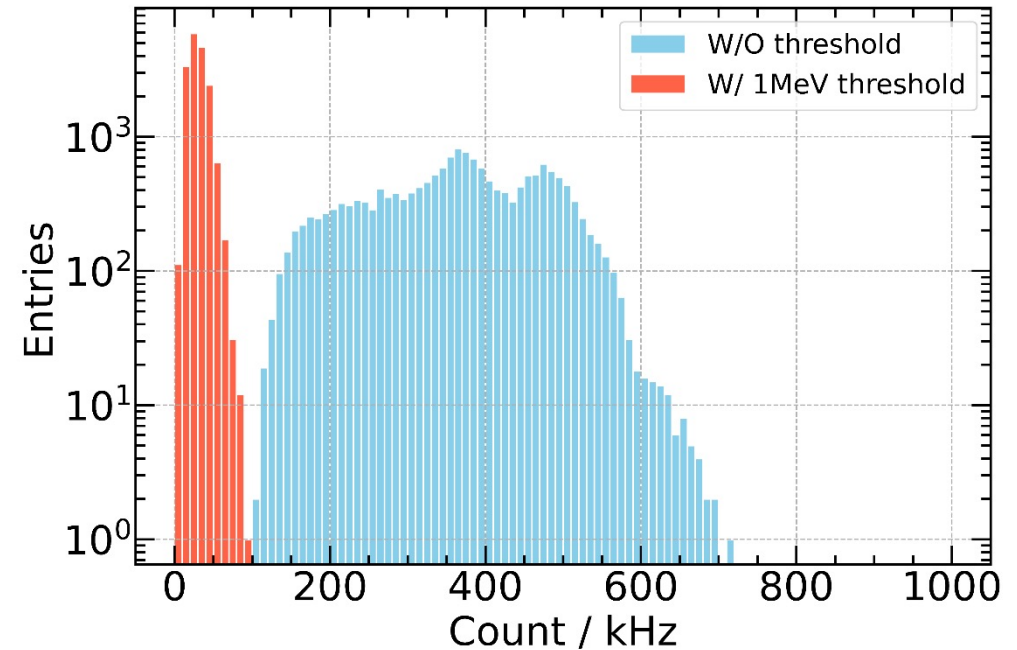
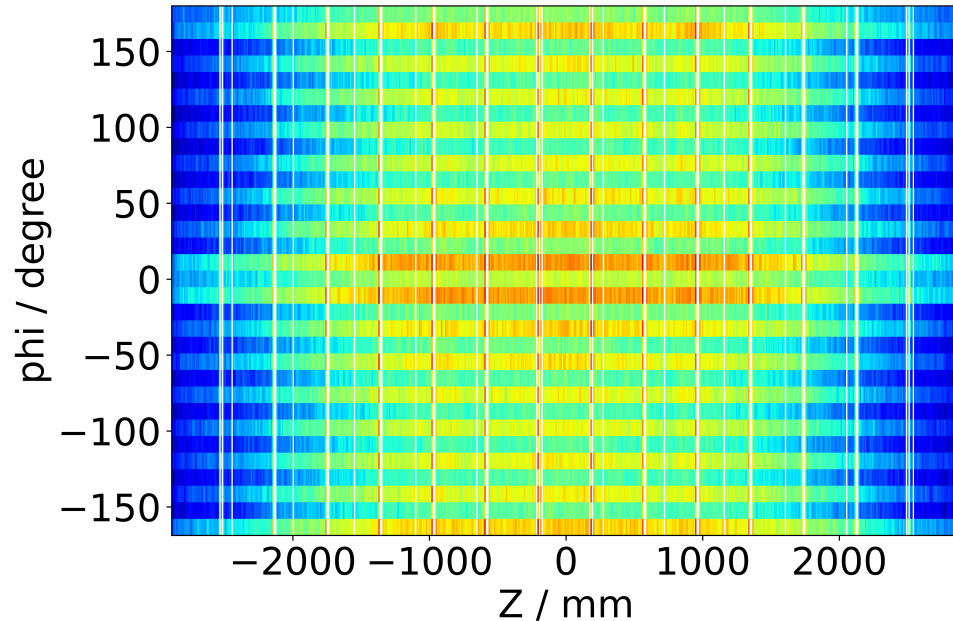

- Simulation studies on beam background in Higgs mode: crystal ECAL barrel
 - Including physics events + backgrounds (major contributions from pair production)
 - With threshold, rate can be significantly reduced: 100kHz (0.1 MIP threshold) from 700kHz (0 threshold)
 - Need to further investigate impacts of pile-ups, and endcap regions

Physics performance in simulation: $H \rightarrow \gamma\gamma$

■ Physics process: $ee \rightarrow ZH \rightarrow \nu\nu\gamma\gamma$ in $\sqrt{s} = 240$ GeV

- Full simulation and digitization, with energy correction in crack regions

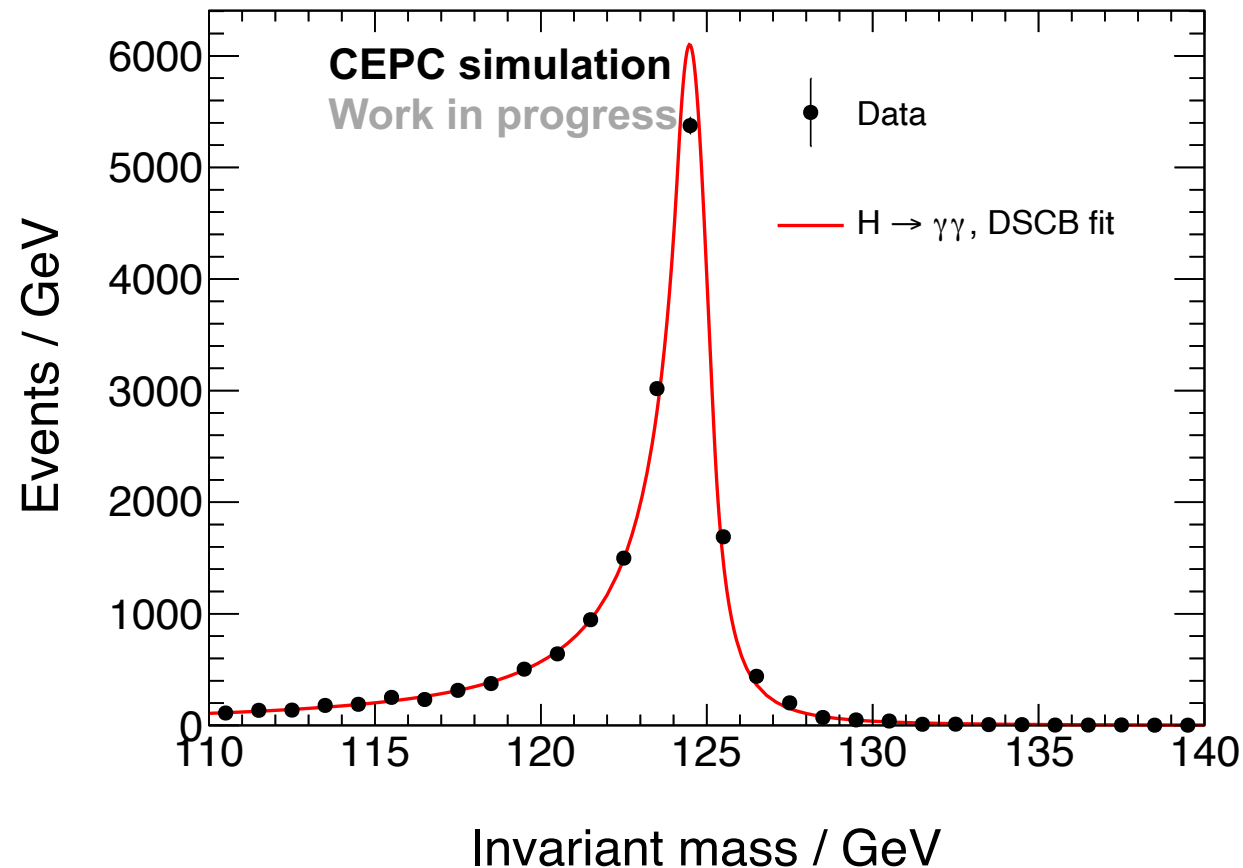

Double-side CB fit, $\sigma(m_{\gamma\gamma}) = 0.57$ GeV

Long tail from

- Lossy processes of crystal calorimeter
- Imperfect correction in crack region.

Can be fixed with better photon energy correction

Physics performance in simulation: $H \rightarrow gg$

- Physics process: $ee \rightarrow ZH \rightarrow \nu\nu gg$ in $\sqrt{s} = 240$ GeV
 - Full reconstruction of two gluon jets in the full CEPC detector
 - Dedicated developments of PFA for long crystal bars

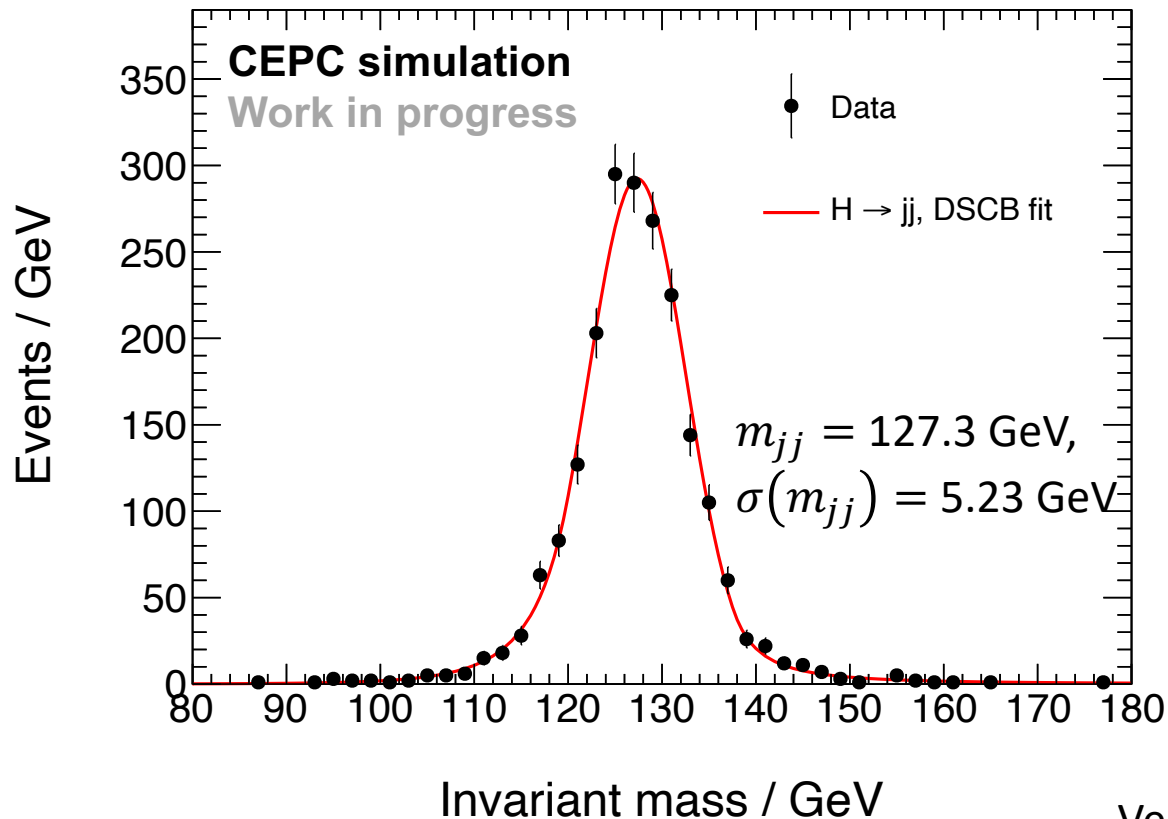

Boson mass resolution (BMR) 4.11%.
With truth track: **BMR 3.73%.**

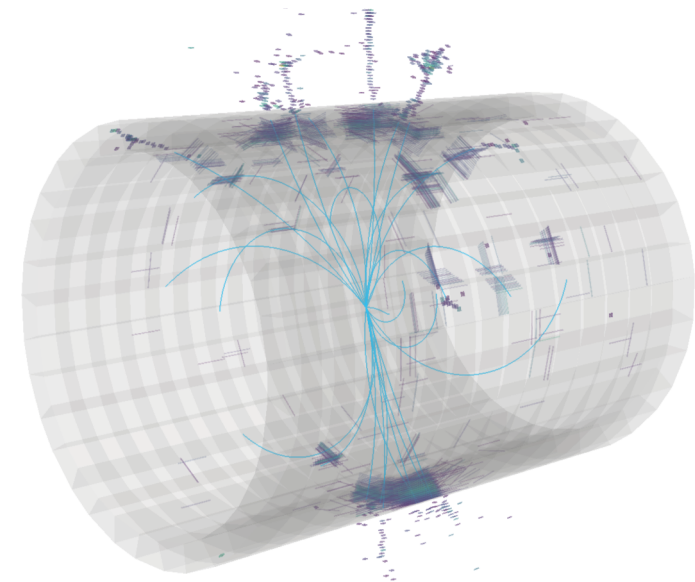

Alternative ECAL design: stereo crystals

Stereo design with long crystal bars inclined

- Simulation studies on reconstruction and separation capability of two particle
- Ongoing designs on mechanics, cooling and integration

Stereo Crystal Electromagnetic Calorimeter: Design

- To improve the 3D position resolution
 - Pointing angle of **even layers** along Z: α
 - Pointing angle of **odd layers** along Z: $\alpha' = -\alpha$

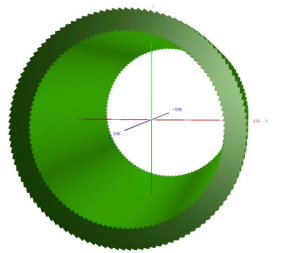
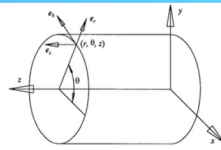

Traditional Crystal Ecal

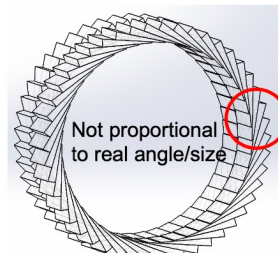
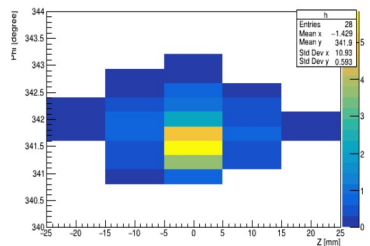

SCEcal

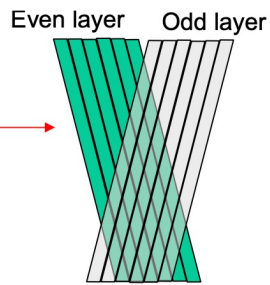
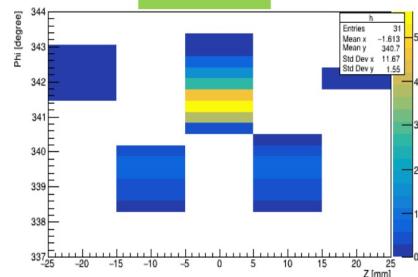

Left eye

Right eye

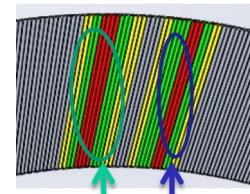

π^+ γ

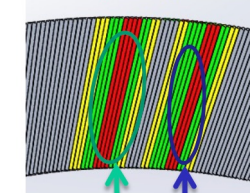

π^- γ

Separation between γ/π

- 5 GeV γ /10GeV π , vary distance along ϕ between them
- Success reconstruction: $3.3\text{GeV} < E_\gamma < 6.6\text{GeV}$
- Different π/γ separation power: pointing angle / magnetic field

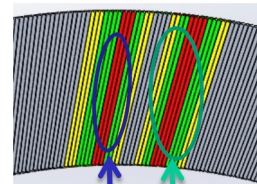
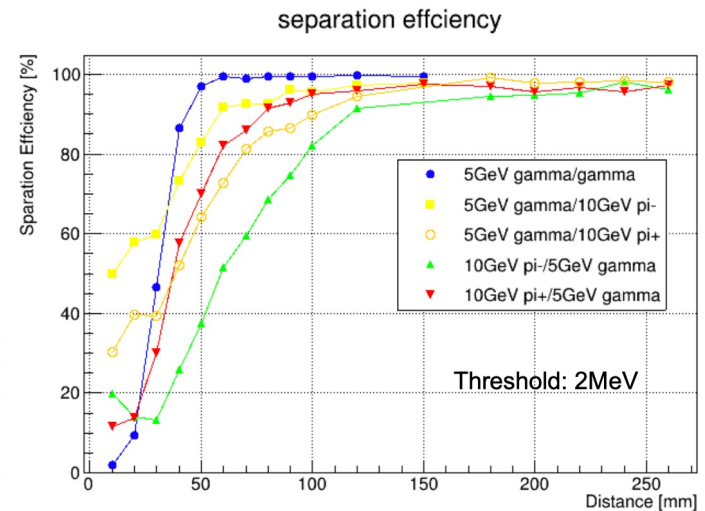

γ π^+

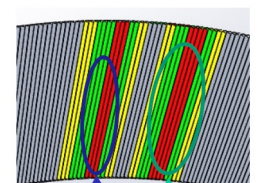

γ π^-

Taskforce and collaborations

■ Taskforce working on CEPC ECAL

- Detector (hardware/software): physicists (8), postdocs (3), students (8)
- Engineers in electronics (3) and mechanics (1)

■ Many members deeply involved in large-scale experiments/projects

- BES-III Experiment: Electromagnetic Calorimeter (EMC) with 6,240 CsI(Tl) crystals
- JUNO Experiment: 20,000 ton ultra-pure liquid scintillator
- CMS HGCAL project for HL-LHC: ~5,000 silicon modules (8-inch)

■ Institutions as working groups in CALICE and DRD6 collaborations

- IHEP, SIC-CAS, SJTU/TDLI, USTC, SCNU
- Shinshu U. and U. Tokyo (on ScW-ECAL option)

Working plan

- Near future activities within 2024 for reference TDR
 - **Beam-induced backgrounds**: simulation in barrel and endcap regions, impacts to physics performance, estimate of data throughput
 - **Mechanics and cooling**: refine FEA simulations, validation by dedicated tests
 - **Detector**: fully exploit beamtest data on EM performance and validation studies
 - **Software**: geometry updates (interplay with mechanics/cooling), digitization (inputs from beamtest and electronics)
 - **Calibration**: sensitive units (SiPM, crystal, ASIC) versus temperature, irradiation
 - **Particle flow performance**: further optimizations

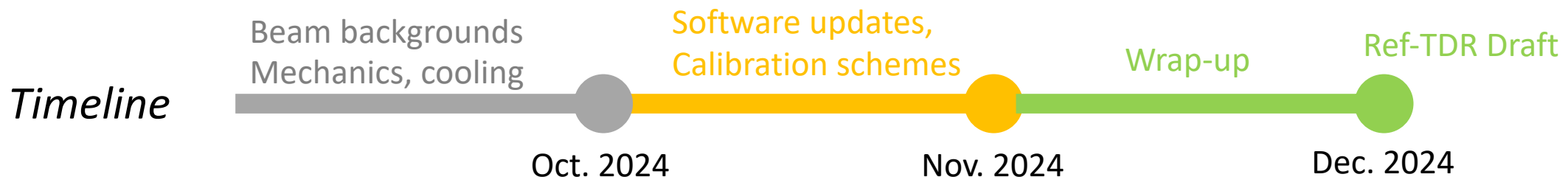

Summary

- Overview of CEPC ECAL options and dedicated R&D in past 8 years
- Crystal selected as a baseline option for the CEPC reference detector
 - Extensive studies on simulation performance and specifications
 - Steady progress with prototyping/beamtests, and dedicated PFA developments
 - First designs of general design, mechanics, cooling and readout electronics
- More efforts in planning to address critical issues for reference detector TDR
 - Beam-induced backgrounds and data throughput
 - System integration issues with mechanics, cooling and readout electronics
 - Calibration schemes (on-board designs for in-situ): SiPM, crystal, ASIC



CEPC

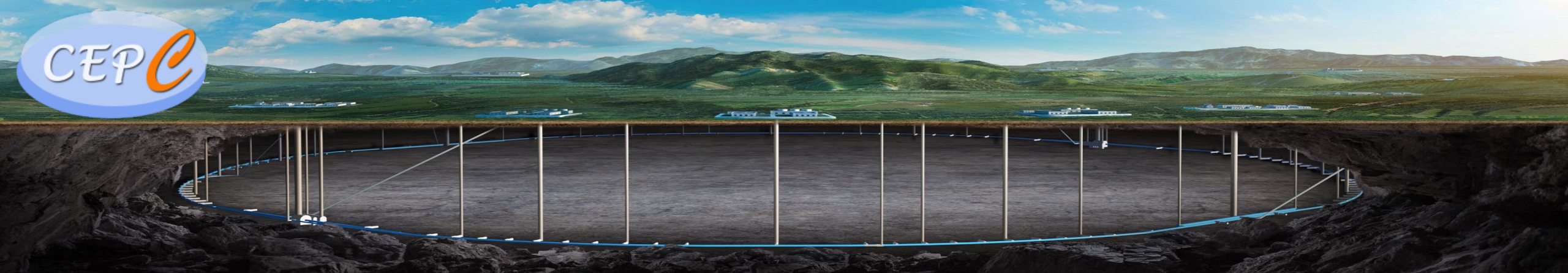

**Thank you for your
attention!**



中國科學院高能物理研究所
Institute of High Energy Physics
Chinese Academy of Sciences

Aug. 7th, 2024, CEPC Detector Ref-TDR Review

References

- C. Adloff et al., Response of the CALICE Si-W electromagnetic calorimeter physics prototype to electrons, Nuclear Instruments and Methods in Physics Research A 608 (2009) 372–383
- K. Francis et al., Performance of the first prototype of the CALICE scintillator strip electromagnetic calorimeter, Nuclear Instruments and Methods in Physics Research A 763 (2014) 278–289
- CEPC Conceptual Design Report Volume II - Physics & Detector, IHEP-CEPC-DR-2018-02

Electronics diagram for ECAL & HCAL

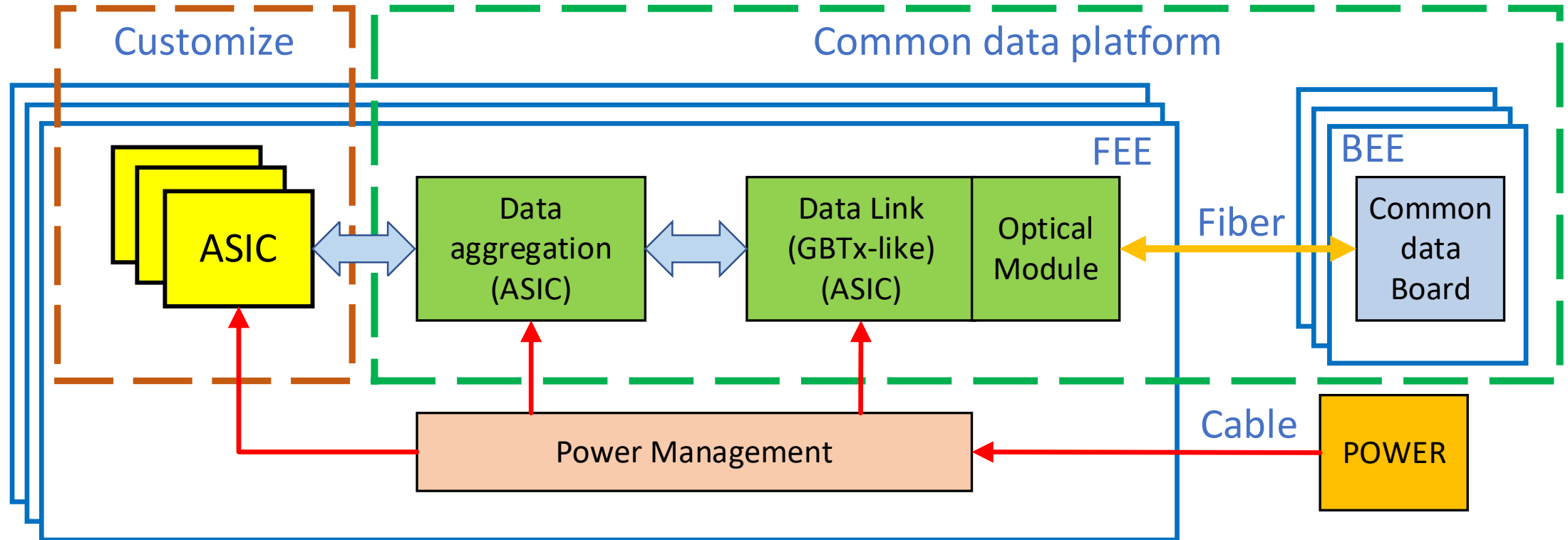

- Energy and time measurements: ASIC for ECAL & HCAL
- Data transmission: common data platform (refer to the “Electronics TDR Report”)
- Trigger mode: trigger-less readout in Front-End Electronics (FEE)

Beam-induced backgrounds: simulation studies

Background	Rate/Hz	$N_{MCParticle} / 3.6 \mu s$ time window
Pair production	---	~ 7800
Beam-Gas Bremsstrahlung (BGB)	83,280.65	~ 0.30
Beam-Gas Coulomb (BGC)	884,002.12	~ 3.18
Beam Thermal Photon Scattering (BTH)	623,520.09	~ 2.24
Synchrotron Radiation	---	---
Radiative Bhabha	---	---
Touschek	---	---

- **Higgs mode:**
 - pair production: double beams, e+
 - BG: single beam
- Using **4 types** of beam backgrounds.
- **Simulation Time Window:** 3.6 us (6 collisions and 6 bunch spacing)
 - Considering physics events and beam background events.
 - Taking into account the scintillation decay time of the crystal and the shaping time of the electronics.

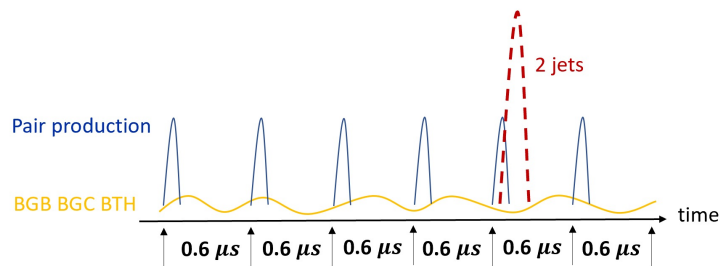

2024/8/5

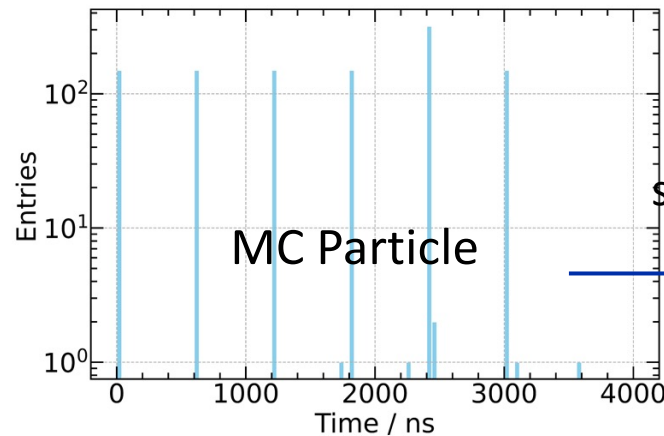

simulation

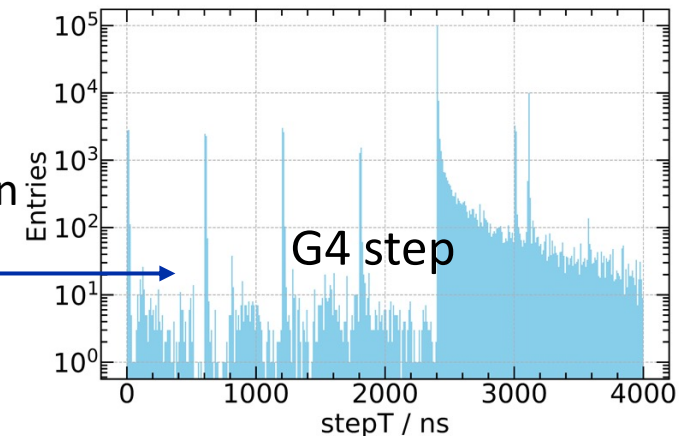

Beam-induced backgrounds: time structures

single crystal bar



step (E, T)

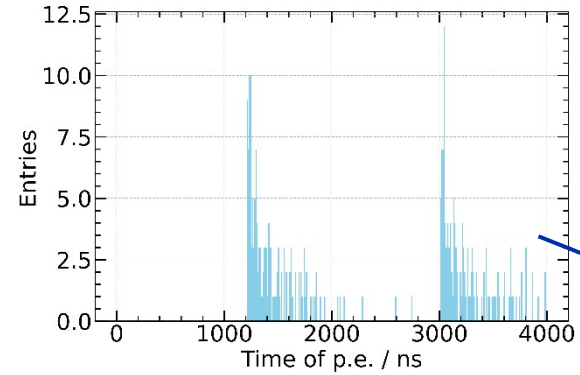
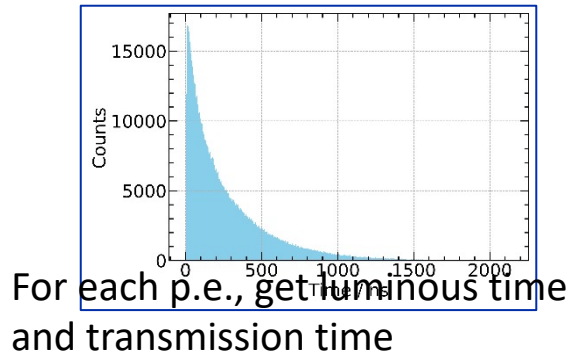
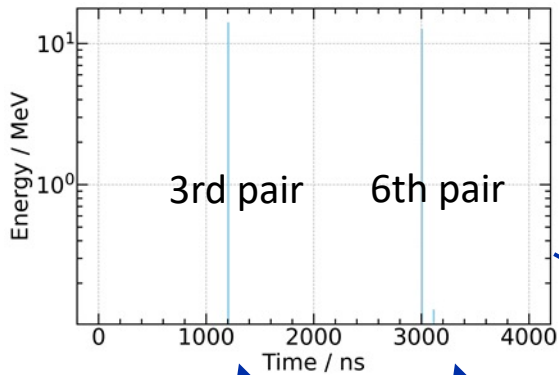

time structure of single crystal with 2 pair production

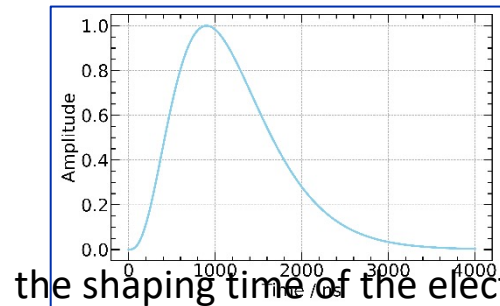
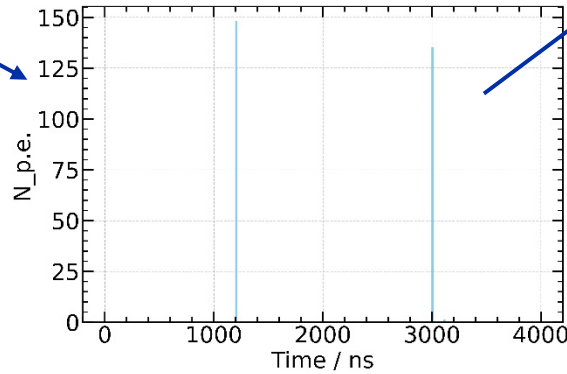
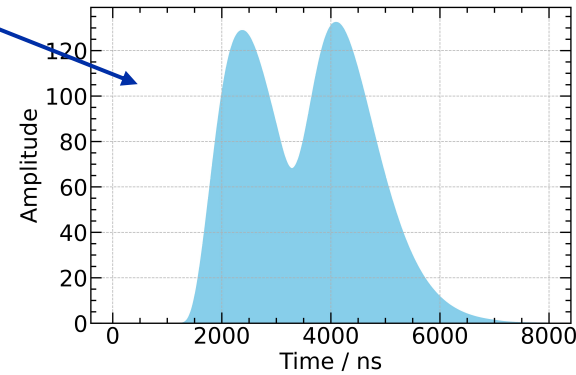

the shaping time of the electronics:
CR-(RC)³

Detected Np.e in SiPM: 100 p.e./Mip

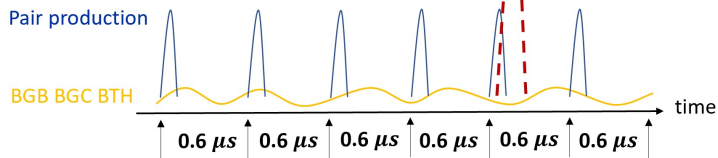

Mechanics: FEA studies on deformation

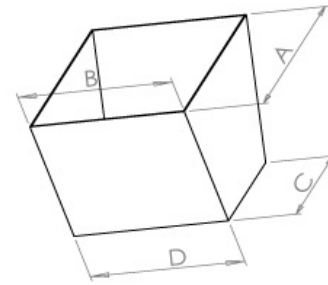
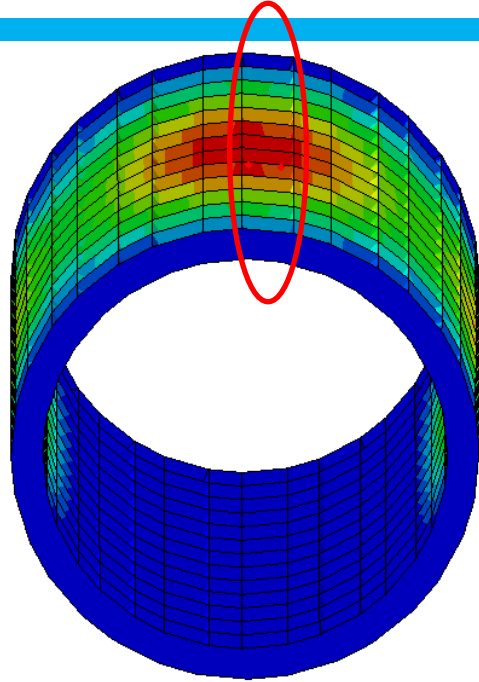
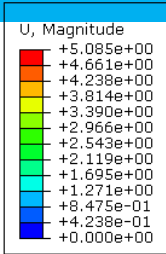

A/B/C/D are the sides of the cell

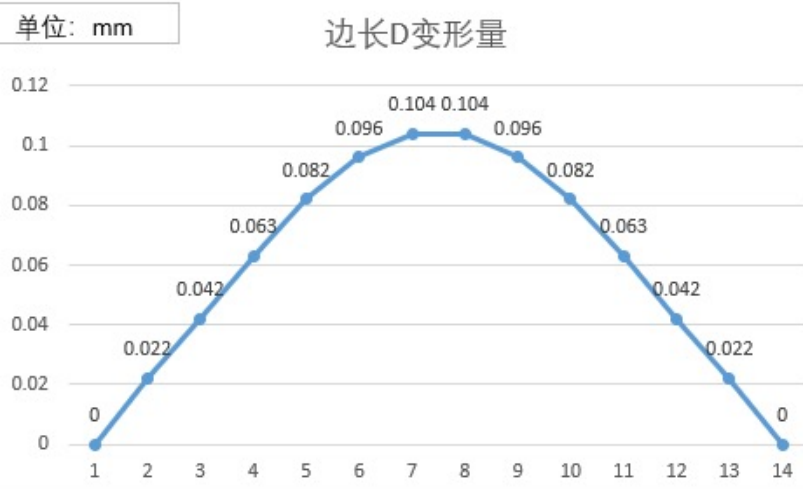
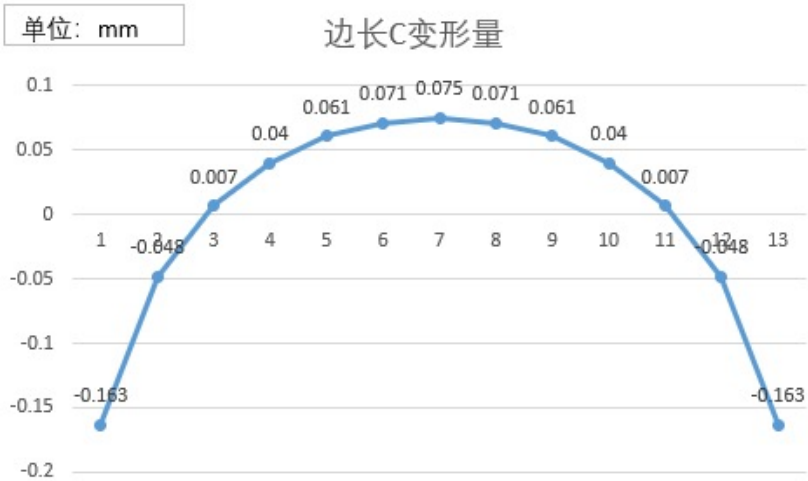
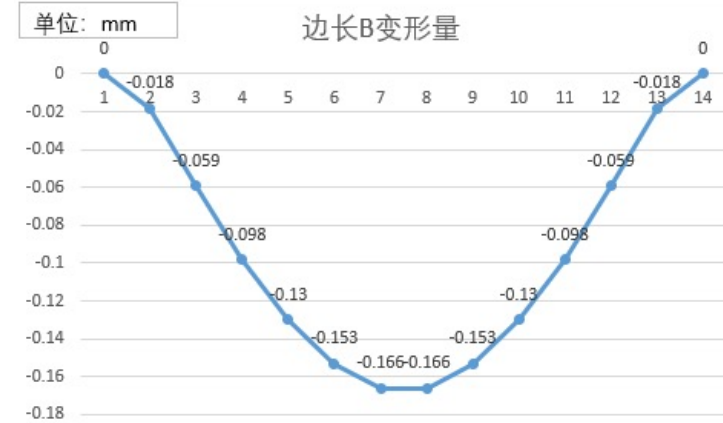
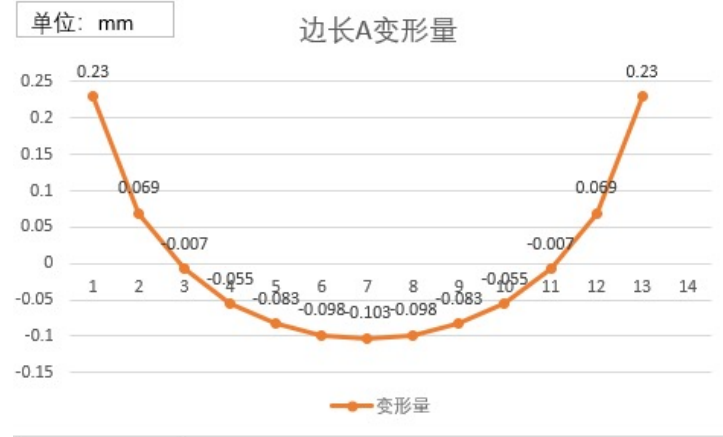

The BGO is brittle, so we have to know the deformation of each cell. According to the FEA, the maximum deformation of the cells is 0.23mm.

CERN setup: energy resolution

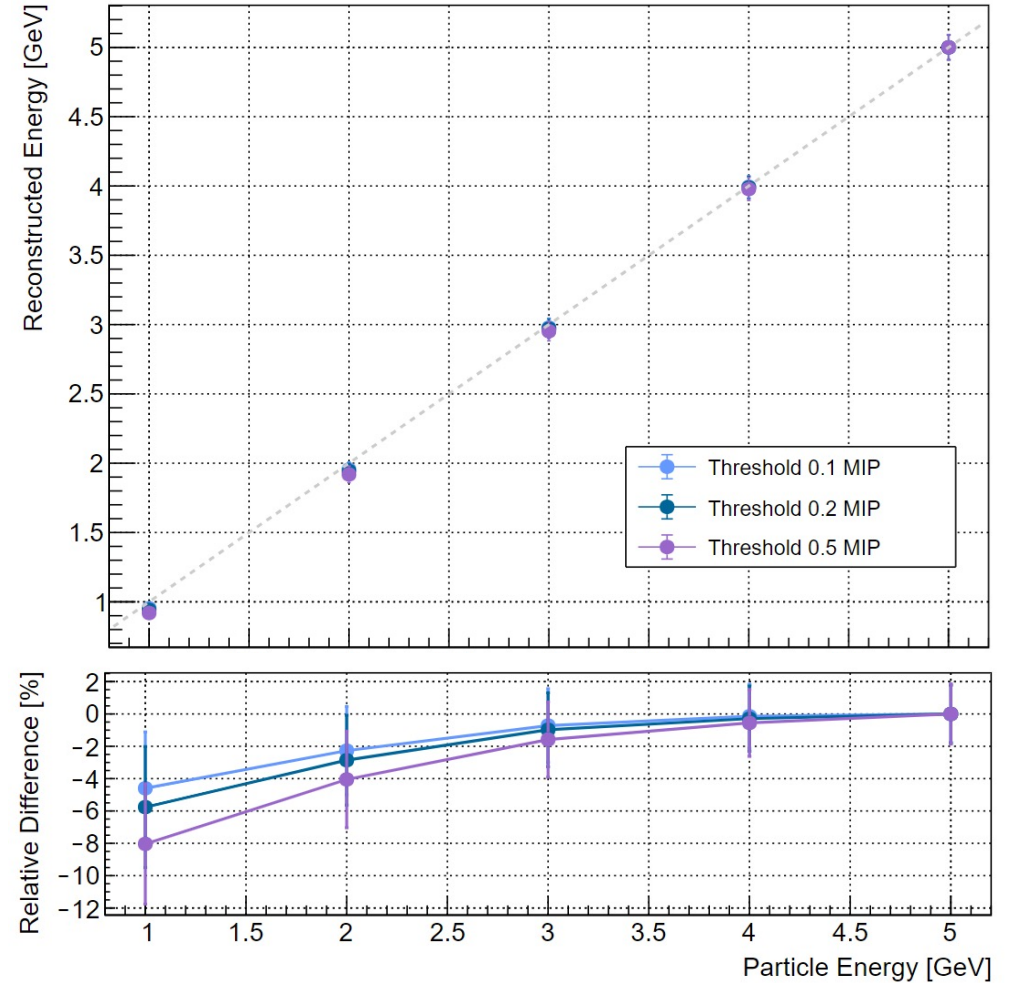
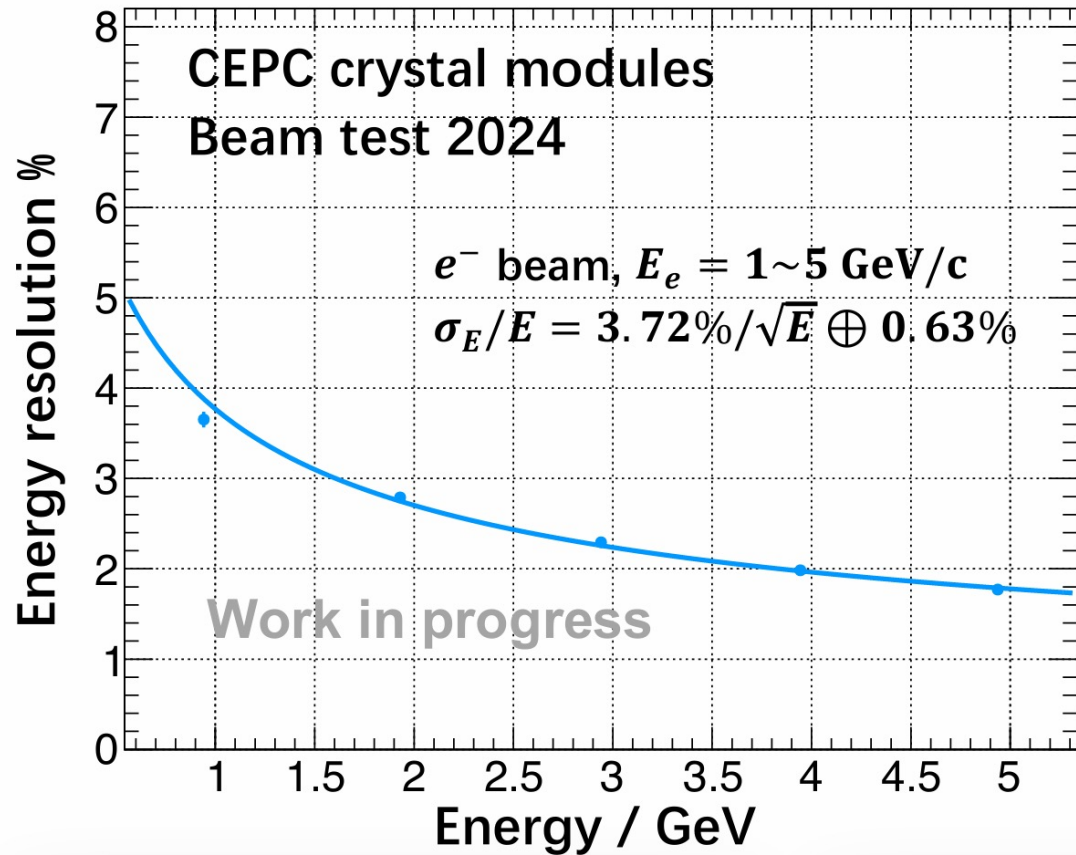

Planning

- R&D planning to address critical issues: beyond 2024
 - Radiation damages in SiPM and crystal: mitigation solutions

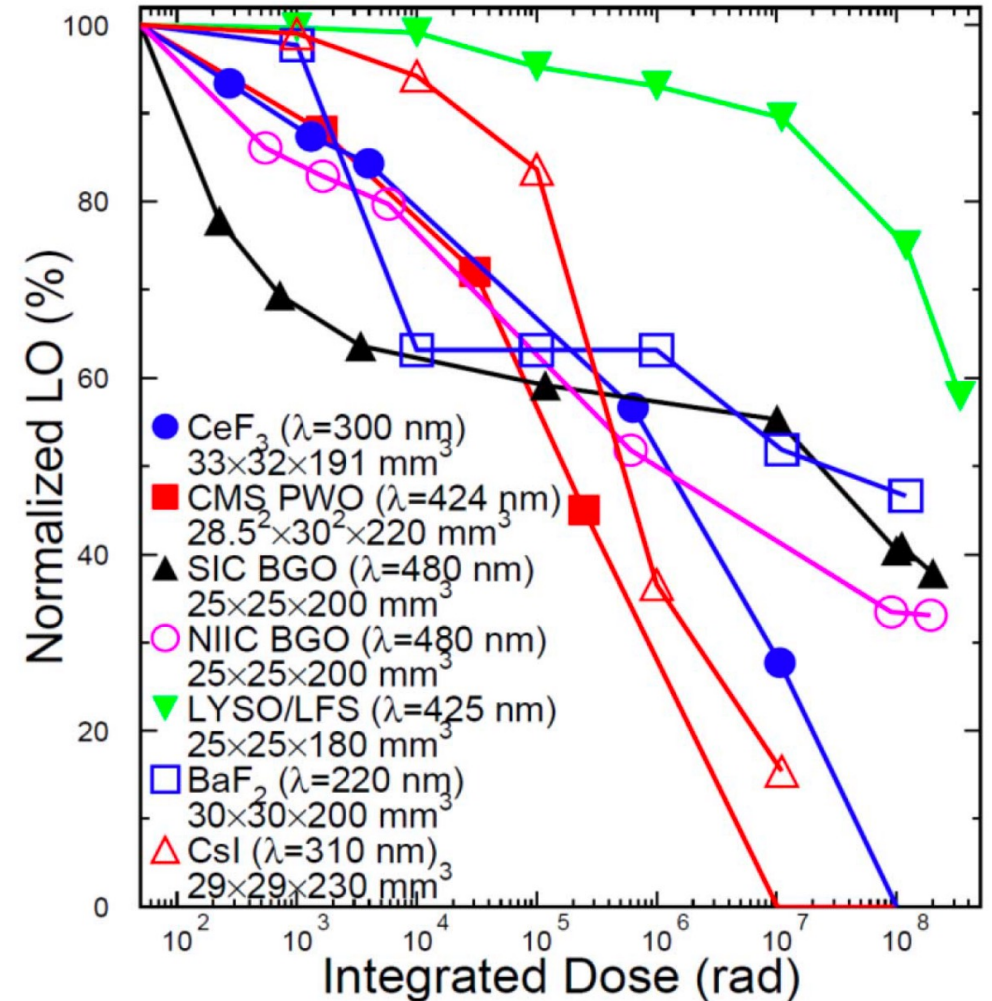

Fig. 21. Normalized LO as a function of integrated dose for various crystals.

1. Geometry design of ECAL barrel

2. Geometry and material description of ECAL barrel

■ Design of 32-side crystal ECAL geometry.

- Invert trapezoid module with minimized crack angle: reduce energy leakage.
- Correspondence of layers between adjacent modules: clear shower structure.

■ A realistic crystal ECAL geometry has been implemented with DD4HEP and released at CEPCSW MR [I9](#).

■ Summary of all crystal ECAL parameters.

■ Fine geometry and material description.

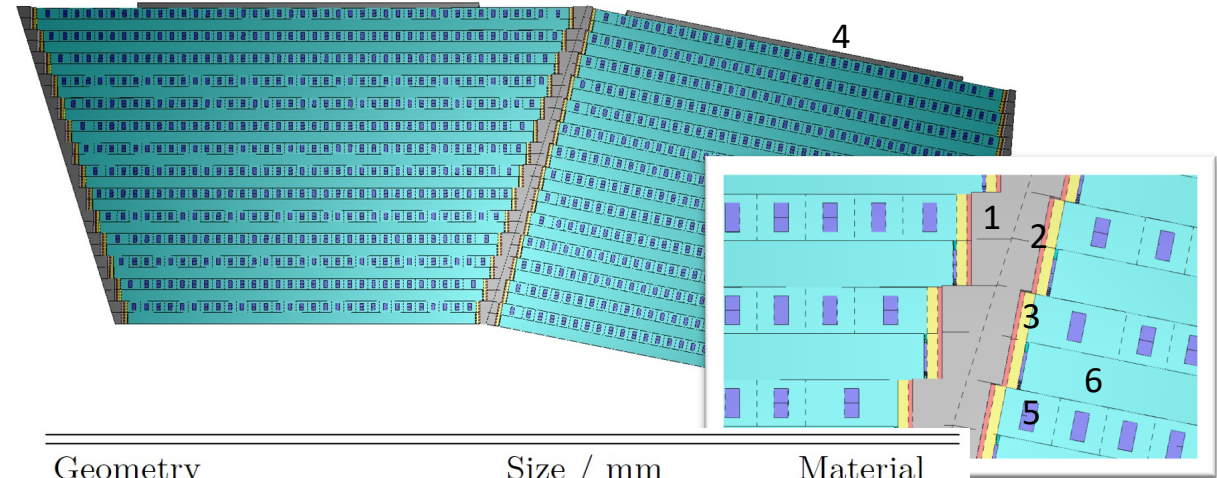
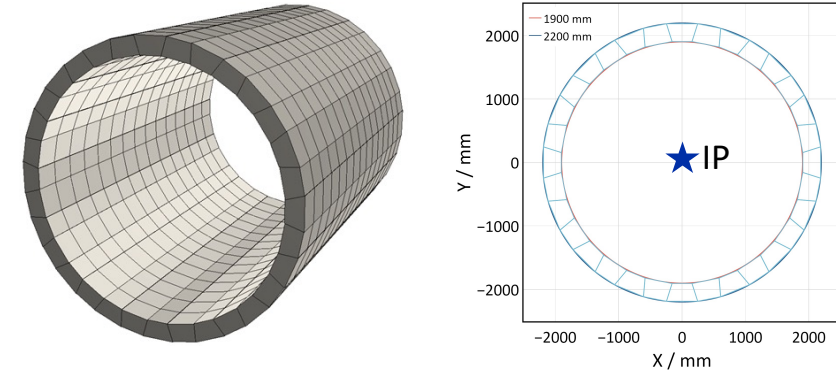

Parameter	Value / mm
Inner radius	1900
Outer radius	2200
Length	5900
Crystal length	~ 400
# Modules in $r - \phi$	32
# Modules in Z	15
ϕ Projectivity tilt	12°
# Layers	28

Parameter / mm	Anti-Trapezoidal	Trapezoidal
Bottom length	314.598	435.106
Top length	492.657	369.809
Module height	280.232	292.216
Layer height	9.651	10.079
Crystal height	9.451	9.879
Radiation length	23.628 X_0	24.698 X_0

Geometry	Size / mm	Material
Supporting ¹	5	carbon fiber
Cooling ²	1	copper
Electronics front end ³	1.2+1	PCB+ASIC
Electronic back board ⁴	10	PCB
Electro-optical device ⁵	3*3*0.8	SiPM
Wrapping ⁶	0.1	ESR
Crystal ⁶	~10*10*400	BGO

Digitization and single photons energy resolution

- Digitization: energy deposition \rightarrow digits in ADC, considering crystal scintillation and electronic design.

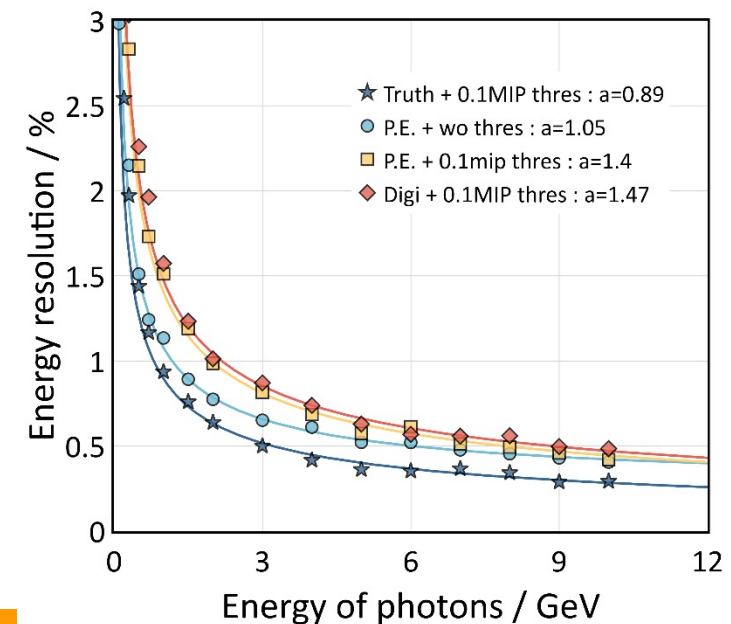
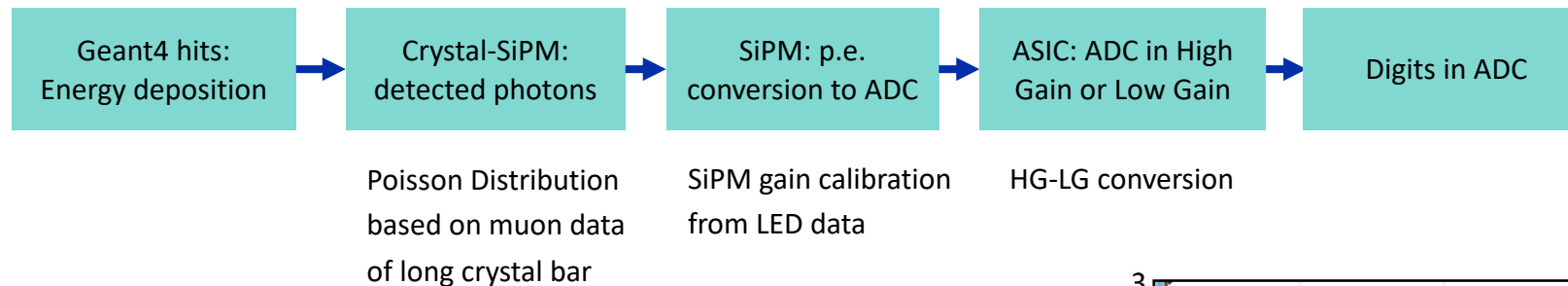

Geometry of ECAL endcap

- 1st version (very preliminary).
- Consist of several same modules, right plot shows single module.
- Dead material (carbon fiber, electronics and so on) is similar v

barrel

Parameter	Value
Inner radius	350 mm
Outer radius	2200 mm
Z start	2930 mm
Z depth	300mm (24 X ₀ 268.8 mm)

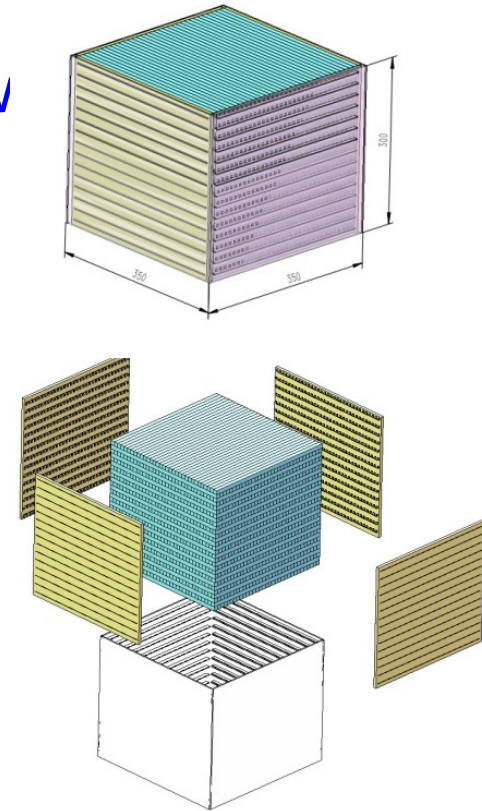
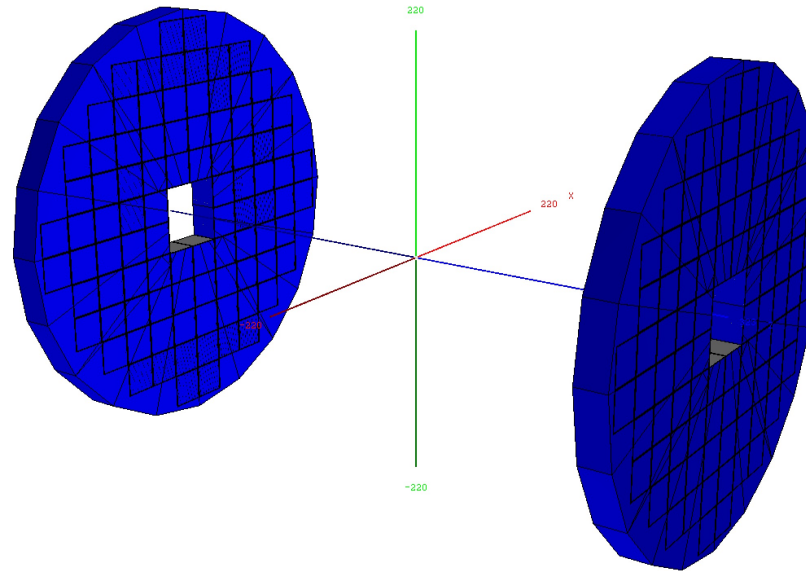

Overall Structure

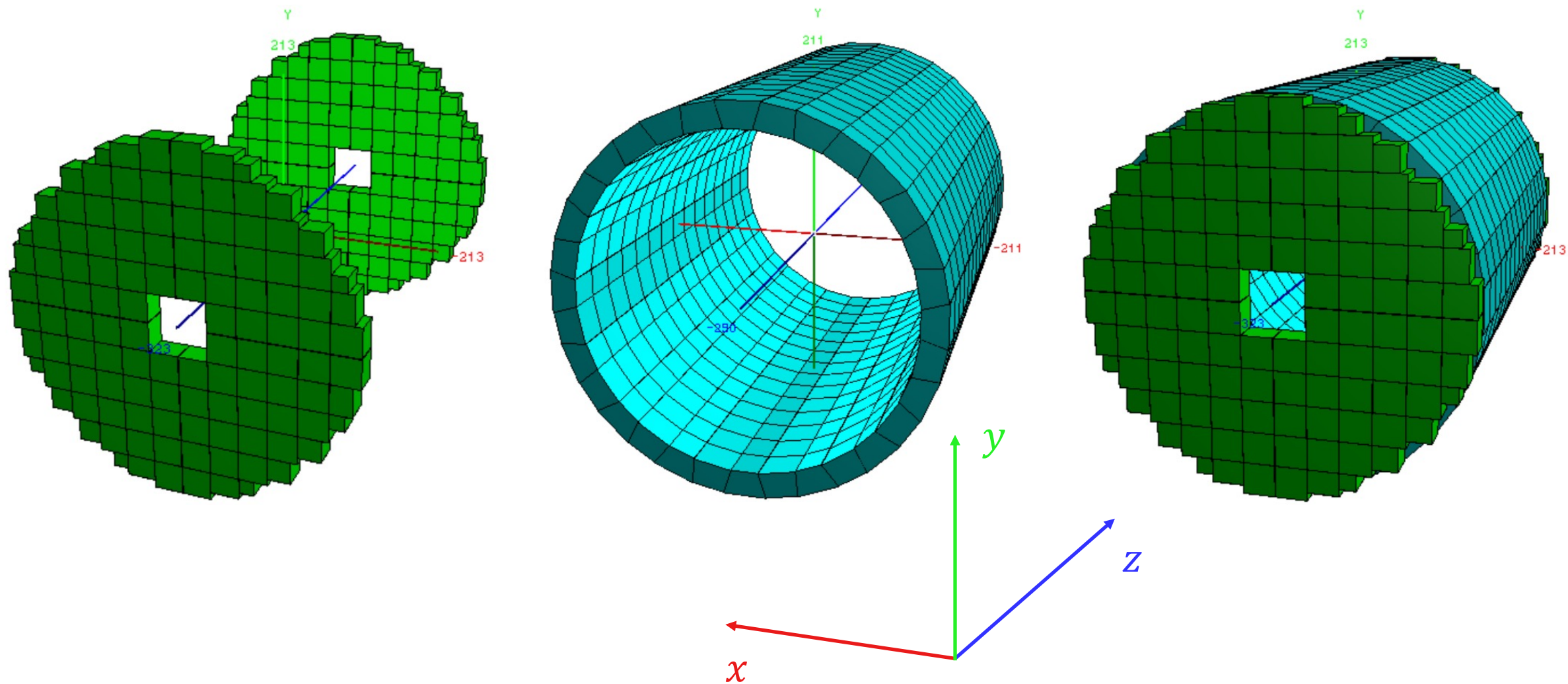

Detailed Design (Barrel)

